



Operator Manual

QSB5-G5, QSB5-G6, and QSB5-G13 Engines with PowerCommand®1.1 Control

C50D6C (Spec A-B)

C60D6C (Spec A-B)

C80D6C (Spec A-B)

C100D6C (Spec A-B)

C125D6C (Spec A)

CALIFORNIA
Proposition 65 Warning

Diesel engine exhaust and some of its constituents are known to the State of California to cause cancer, birth defects, and other reproductive harm.

Table of Contents

| | |
|--|-----|
| 1. IMPORTANT SAFETY INSTRUCTIONS | 1 |
| 1.1 Warning, Caution, and Note Styles Used in This Manual | 1 |
| 1.2 General Information | 1 |
| 1.3 Generator Set Safety Code | 4 |
| 1.4 Moving Parts Can Cause Severe Personal Injury or Death | 4 |
| 1.5 Electrical Shocks and Arc Flashes Can Cause Severe Personal Injury or Death..... | 5 |
| 1.6 Fuel and Fumes Are Flammable | 5 |
| 1.7 Batteries Can Explode | 6 |
| 1.8 Exhaust Gases Are Deadly..... | 7 |
| 1.9 The Hazards of Carbon Monoxide..... | 9 |
| 1.10 Earth Ground Connection | 9 |
| 2. INTRODUCTION..... | 11 |
| 2.1 Safety..... | 11 |
| 2.2 About This Manual..... | 11 |
| 2.3 Schedule of Abbreviations | 12 |
| 2.4 Related Literature | 14 |
| 2.5 Model Specifications | 15 |
| 2.6 After Sales Services..... | 22 |
| 3. CONTROL SYSTEM - POWERCOMMAND 1.1..... | 27 |
| 3.1 Control System Description | 27 |
| 3.2 Selecting Operating Modes..... | 48 |
| 3.3 Operating Modes | 53 |
| 4. OPERATION - POWERCOMMAND 1.1 | 55 |
| 4.1 Safety..... | 55 |
| 4.2 Introduction | 56 |
| 4.3 Operating Recommendations | 56 |
| 4.4 Generator Set Operation..... | 59 |
| 4.5 Before Starting | 68 |
| 4.6 Stopping..... | 71 |
| 5. MAINTENANCE | 75 |
| 5.1 Maintenance Safety | 75 |
| 5.2 Periodic Maintenance | 78 |
| 5.3 Cooling System..... | 83 |
| 5.4 Engine Oil | 84 |
| 5.5 Diesel Fuel System Safety and Requirements | 89 |
| 5.6 Air Intake System..... | 95 |
| 5.7 Exhaust System Maintenance | 99 |
| 5.8 Generator Set Output - AC Electric System Checks | 100 |
| 5.9 DC Electrical System | 101 |

| | |
|---|-----|
| 5.10 Batteries | 101 |
| 5.11 Cleaning the Generator Set Housing | 105 |
| 5.12 Complete System Test | 105 |
| 6. TROUBLESHOOTING | 107 |
| 6.1 Fault Code Introduction..... | 107 |
| 6.2 Avoiding Generator Set Shutdowns | 107 |
| 6.3 Control System | 107 |
| 6.4 Safety Considerations..... | 108 |
| 6.5 Fault Finding | 109 |
| 6.6 Engine Does Not Crank in Manual Mode (No Fault Message) | 110 |
| 6.7 Code 143 - Engine Oil Pressure Low (Warning) | 110 |
| 6.8 Code 146 - Engine Coolant Temperature Above Normal (Warning)..... | 110 |
| 6.9 Code 151 - Engine Coolant Temperature High (Shutdown)..... | 111 |
| 6.10 Code 415 - Engine Oil Pressure Low (Shutdown)..... | 113 |
| 6.11 Code 441 - Battery Voltage Low (Warning)..... | 113 |
| 6.12 Code 1317 - Coolant Level Low (Warning or Shutdown) | 113 |
| 6.13 Code 1318 - Low Fuel (Warning or Shutdown) | 114 |
| 6.14 Code 1438 - Fail to Crank (Shutdown)..... | 114 |
| 6.15 Code 1471 - High AC Current (Warning)..... | 114 |
| 6.16 Code 1472 - High AC Current (Shutdown)..... | 115 |
| 6.17 Code 5134 - Unknown Shutdown at Idle | 115 |
| 6.18 Status Indicators - PowerCommand 1.1 | 116 |
| 6.19 Fault/Status Codes - PowerCommand 1.1 | 117 |
| 6.20 Line Circuit Breaker | 118 |

1 IMPORTANT SAFETY INSTRUCTIONS

SAVE THESE INSTRUCTIONS. This manual contains important instructions that should be followed during installation and maintenance of the generator set and batteries.

Safe and efficient operation can be achieved only if the equipment is properly operated and maintained. Many accidents are caused by failure to follow fundamental rules and precautions.

1.1 Warning, Caution, and Note Styles Used in This Manual

The following safety styles and symbols found throughout this manual indicate potentially hazardous conditions to the operator, service personnel, or equipment.

DANGER

Indicates a hazardous situation that, if not avoided, will result in death or serious injury.

WARNING

Indicates a hazardous situation that, if not avoided, could result in death or serious injury.

CAUTION

Indicates a hazardous situation that, if not avoided, could result in minor or moderate injury.

NOTICE

Indicates information considered important, but not hazard-related (e.g., messages relating to property damage).

1.2 General Information

This manual should form part of the documentation package supplied by Cummins Inc. with specific generator sets. If this manual has been supplied in isolation, please contact your authorized dealer.

NOTICE

It is in the operator's interest to read and understand all warnings and cautions contained in the documentation relevant to the generator set operation and daily maintenance.

General Safety Precautions

WARNING

Hot Pressurized Liquid

Contact with hot liquid can cause severe burns.

Do not open the pressure cap while the engine is running. Let the engine cool down before removing the cap. Turn the cap slowly and do not open it fully until the pressure has been relieved.

WARNING

Moving Parts

Moving parts can cause severe personal injury.

Use extreme caution around moving parts. All guards must be properly fastened to prevent unintended contact.

WARNING

Toxic Hazard

Used engine oils have been identified by some state and federal agencies to cause cancer or reproductive toxicity.

Do not ingest, breathe the fumes, or contact used oil when checking or changing engine oil. Wear protective gloves and face guard.

WARNING

Electrical Generating Equipment

Incorrect operation and maintenance can result in severe personal injury or death.

Do not operate equipment when fatigued, or after consuming any alcohol or drug.

Make sure that only suitably trained and experienced service personnel perform electrical and/or mechanical service.

WARNING

Toxic Gases

Substances in exhaust gases have been identified by some state and federal agencies to cause cancer or reproductive toxicity.

Do not breathe in or come into contact with exhaust gases.

WARNING

High Noise Level

Generator sets in operation emit noise, which can cause hearing damage.

Wear appropriate ear protection at all times.

⚠ WARNING**Hot Surfaces**

Contact with hot surfaces can cause severe burns.

The unit is to be installed so that the risk of hot surface contact by people is minimized. Wear appropriate PPE when working on hot equipment and avoid contact with hot surfaces.

⚠ WARNING**Toxic Hazard**

Ethylene glycol, used as an engine coolant, is toxic to humans and animals.

Wear appropriate PPE. Clean up coolant spills and dispose of used coolant in accordance with local environmental regulations.

⚠ WARNING**Combustible Liquid**

Ignition of combustible liquids is a fire or explosion hazard which can cause severe burns or death.

Do not store fuel, cleaners, oil, etc., near the generator set. Do not use combustible liquids like ether.

⚠ WARNING**Combustible Gases**

Generator sets in operation have combustible gases under pressure, which if ignited can cause eye and ear damage.

Wear appropriate eye and ear protection at all times.

⚠ WARNING**Combustible Gases**

Generator sets in operation have combustible gases under pressure, which if ignited can cause severe injury.

Do not operate the generator set with any doors open.

⚠ WARNING**Fire Hazard**

Materials drawn into the generator set, as well as accumulated grease and oil, are a fire hazard. Fire can cause severe burns or death.

Keep the generator set and the surrounding area clean and free from obstructions. Make sure the generator set is mounted in a manner to prevent combustible materials from accumulating under the unit.

⚠ WARNING***Automated Machinery***

Accidental or remote starting of the generator set can cause severe personal injury or death.

Isolate all auxiliary supplies and use an insulated wrench to disconnect the starting battery cables (negative [-] first).

NOTICE

Keep multi-type ABC fire extinguishers close by. Class A fires involve ordinary combustible materials such as wood and cloth. Class B fires involve combustible and flammable liquid fuels and gaseous fuels. Class C fires involve live electrical equipment. (Refer to NFPA No. 10 in the applicable region.)

NOTICE

Before performing maintenance and service procedures on enclosed generator sets, make sure the service access doors are secured open.

NOTICE

Stepping on the generator set can cause parts to bend or break, leading to electrical shorts, or to fuel leaks, coolant leaks, or exhaust leaks. Do not step on the generator set when entering or leaving the generator set room.

1.3 Generator Set Safety Code

Before operating the generator set, read the manuals and become familiar with them and the equipment. **Safe and efficient operation can be achieved only if the equipment is properly operated and maintained.** Many accidents are caused by failure to follow fundamental rules and precautions.

⚠ WARNING***Electrical Generating Equipment***

Incorrect operation and maintenance can result in severe personal injury or death.

Read and follow all Safety Precautions, Warnings, and Cautions throughout this manual and the documentation supplied with the generator set.

1.4 Moving Parts Can Cause Severe Personal Injury or Death

- Keep hands, clothing, and jewelry away from moving parts.

- Before starting work on the generator set, disconnect the battery charger from its AC source, then disconnect the starting batteries using an insulated wrench, negative (–) cable first. This will prevent accidental starting.
- Make sure that fasteners on the generator set are secure. Tighten supports and clamps; keep guards in position over fans, drive belts, etc.
- Do not wear loose clothing or jewelry in the vicinity of moving parts or while working on electrical equipment. Loose clothing and jewelry can become caught in moving parts.
- If any adjustments must be made while the unit is running, use extreme caution around hot manifolds, moving parts, etc.

1.5 Electrical Shocks and Arc Flashes Can Cause Severe Personal Injury or Death

- Only qualified service personnel certified and authorized to work on power circuits should work on exposed energized power circuits.
- All relevant service material must be available for any electrical work performed by certified service personnel.
- Exposure to energized power circuits with potentials of 50 VAC or 75 VDC or higher poses a significant risk of electrical shock and electrical arc flash.
- Refer to standard NFPA 70E, or equivalent safety standards in corresponding regions, for details of the dangers involved and for safety requirements.

1.6 Fuel and Fumes Are Flammable

Fire, explosion, and personal injury or death can result from improper practices.

- Do not fill fuel tanks while the engine is running unless the tanks are outside the engine compartment. Fuel contact with hot engine or exhaust is a potential fire hazard.
- Do not permit any flame, cigarette, pilot light, spark, arcing equipment, or other ignition source near the generator set or fuel tank.
- Fuel lines must be adequately secured and free of leaks. Fuel connection at the engine should be made with an approved flexible line. Do not use copper piping on flexible lines as copper will become brittle if continuously vibrated or repeatedly bent.
- Make sure all fuel supplies have a positive shutoff valve.
- Make sure the battery area has been well-ventilated prior to servicing near it. Lead-acid batteries emit a highly explosive hydrogen gas that can be ignited by arcing, sparking, smoking, etc.

Do Not Operate in Flammable and Explosive Environments

Flammable vapor can cause an engine to over speed and become difficult to stop, resulting in possible fire, explosion, severe personal injury, and death. Do not operate a generator set where a flammable vapor environment can be created, unless the generator set is equipped with an automatic safety device to block the air intake and stop the engine. The owners and operators of the generator set are solely responsible for operating the generator set safely. Contact your authorized Cummins distributor for more information.

Spillage

Any spillage that occurs during fueling, oil top-off, or oil change must be cleaned up before starting the generator set.

Spillage

Any spillage that occurs during oil top-off or oil change must be cleaned up before starting the generator set.

Fluid Containment

NOTICE

Where spillage containment is not part of a Cummins supply, it is the responsibility of the installer to provide the necessary containment to prevent contamination of the environment, especially water courses and sources.

If fluid containment is incorporated into the bedframe, it must be inspected at regular intervals. Any liquid present should be drained out and disposed of in line with local health and safety regulations. Failure to perform this action may result in spillage of liquids which could contaminate the surrounding area.

Any other fluid containment area must also be checked and emptied, as described above.

1.7 Batteries Can Explode

Batteries can explode, causing severe skin and eye burns and can release toxic electrolytes.

WARNING

Combustible Gases

Batteries can explode, causing severe skin and eye burns, and can release toxic electrolytes.

Do not dispose of the battery in a fire, because it is capable of exploding. Do not open or mutilate the battery. Do not charge frozen batteries.

⚠ WARNING***Electric Shock Hazard******Batteries present the risk of high short circuit current.******When servicing the generator set:***

- ***Remove watches, rings, or other metal objects.***
- ***Use tools with insulated handles.***

NOTICE**Service of batteries must be performed or supervised by personnel knowledgeable of batteries and the required precautions. Keep unauthorized personnel away from batteries.**

- Wear safety glasses.
- Do not smoke.
- Do not charge frozen batteries.
- To prevent arcing when disconnecting the battery:
 1. Press the Off switch from the display and then press the E-Stop button.
 2. Disconnect AC power from any battery chargers.
 3. Remove the negative (-) battery cables to prevent starting.
- To prevent arcing when reconnecting the battery:
 1. Reconnect the positive (+) cables.
 2. Reconnect the negative (-) cables.
 3. Reconnect the battery charger to AC power supply.
- When replacing the generator set battery, always replace it with a battery as specified in this manual.

1.8 Exhaust Gases Are Deadly

- Provide an adequate exhaust system to properly expel discharged gases away from enclosed or sheltered areas, and areas where individuals are likely to congregate. Visually and audibly inspect the exhaust system daily for leaks per the maintenance schedule. Make sure that exhaust manifolds are secured and not warped. Do not use exhaust gases to heat a compartment.
- Make sure the unit is well ventilated.

Exhaust Precautions

WARNING

Hot Exhaust Gases

Contact with hot exhaust gases can cause severe burns.

Wear personal protective equipment when working on equipment.

WARNING

Hot Surfaces

Contact with hot surfaces can cause severe burns.

The unit is to be installed so that the risk of hot surface contact by people is minimized. Wear appropriate PPE when working on hot equipment and avoid contact with hot surfaces.

WARNING

Toxic Gases

Inhalation of exhaust gases can cause asphyxiation and death.

Pipe exhaust gas outside and away from windows, doors, or other inlets to buildings. Do not allow exhaust gas to accumulate in habitable areas.

WARNING

Fire Hazard

Contaminated insulation is a fire hazard. Fire can cause severe burns or death.

Remove any contaminated insulation and dispose of it in accordance with local regulations.

The exhaust outlet may be sited at the top or bottom of the generator set. Make sure that the exhaust outlet is not obstructed. Personnel using this equipment must be made aware of the exhaust position. Position the exhaust away from flammable materials - in the case of exhaust outlets at the bottom, make sure that vegetation is removed from the vicinity of the exhaust.

The exhaust pipes may have some insulating covers fitted. If these covers become contaminated they must be replaced before the generator set is run.

To minimize the risk of fire, make sure the following steps are observed:

- Make sure that the engine is allowed to cool thoroughly before performing maintenance or operation tasks.
- Clean the exhaust pipe thoroughly.

1.9 The Hazards of Carbon Monoxide

Carbon monoxide (CO) is an odorless, colorless, tasteless and non-irritating gas. You cannot see it or smell it. Red blood cells, however, have a greater affinity for CO than for oxygen. Therefore, exposure even to low levels of CO for a prolonged period can lead to asphyxiation (lack of oxygen) resulting in death. Mild effects of CO poisoning include eye irritation, dizziness, headaches, fatigue and the inability to think clearly. More extreme symptoms include vomiting, seizures and collapse.

Engine-driven generator sets produce harmful levels of carbon monoxide that can injure or kill you.

Special Risks of CO near the Home

WARNING

Toxic Gases

Carbon monoxide (CO) gas can cause nausea, fainting, or death. Residents can be exposed to lethal levels of CO when the generator set is running. Depending on air temperature and wind, CO can accumulate in or near the home.

To protect yourself and others from the dangers of CO poisoning, it is recommended that reliable, approved, and operable CO detector alarms are installed in proper locations in the home as specified by their manufacturer.

Protecting Yourself from CO Poisoning

- Locate the generator set in an area where there are no windows, doors, or other access points into the home.
- Make sure all CO detectors are installed and working properly.
- Pay attention for signs of CO poisoning.
- Check the exhaust system for corrosion, obstruction, and leaks every time you start the generator set and every eight hours when you run it continuously.

1.10 Earth Ground Connection

The neutral of the generator set may be required to be bonded to earth ground at the generator set location, or at a remote location, depending on system design requirements. Consult the engineering drawings for the facility or a qualified electrical design engineer for proper installation.

NOTICE

The end user is responsible to make sure that the ground connection point surface area is clean and free of rust before making a connection.

NOTICE

The end user is responsible for making sure that an earthing arrangement that is compliant with local conditions is established and tested before the equipment is used.

2 Introduction

2.1 Safety

 **WARNING**

Hazardous Voltage

Contact with high voltages can cause severe electrical shock, burns, or death.

Make sure that only a trained and experienced electrician makes generator set electrical output connections, in accordance with the installation instructions and all applicable codes.

 **WARNING**

Electrical Generating Equipment

Faulty electrical generating equipment can cause severe personal injury or death.

Generator sets must be installed, certified, and operated by trained and experienced person in accordance with the installation instructions and all applicable codes.

2.2 About This Manual

The purpose of this manual is to provide the users with sound, general information. It is for guidance and assistance with recommendations for correct and safe procedures. Cummins Inc. cannot accept any liability whatsoever for problems arising as a result of following recommendations in this manual.

The information contained within the manual is based on information available at the time of going to print. In line with Cummins Inc. policy of continuous development and improvement, information may change at any time without notice. The users should therefore make sure that they have the latest information available before starting any work. The latest version of this manual is available on QuickServe Online (<https://quickserve.cummins.com>).

Users are respectfully advised that, in the interests of good practice and safety, it is their responsibility to employ competent people to carry out any installation work. Consult your authorized dealer for further installation information. It is essential that the utmost care is taken with the application, installation, and operation of any generator set due to their potentially hazardous nature. Careful reference should also be made to other Cummins Inc. literature. You must operate and maintain your generator set properly if you are to expect safe and reliable operation.

For further assistance, contact your authorized Cummins Inc. dealer.

NOTICE

This device complies with part 15 of the FCC rules. Operation is subject to the following two conditions:

- This device may not cause harmful interferences.
- This device must accept any interference received, including interference that may cause undesired operation.

2.3 Schedule of Abbreviations

This list is not exhaustive. For example, it does not identify units of measure or acronyms that appear only in parameters, event/fault names, or part/accessory names.

| Abbr. | Description | Abbr. | Description |
|-------|---|--------------|---------------------------------|
| AC | Alternating Current | LED | Light-Emitting Diode |
| AMP | AMP, Inc. (part of Tyco Electronics) | MFM | Multifunction Monitor |
| ANSI | American National Standards Institute | Mil Std | Military Standard |
| ASOV | Automatic Shut Off Valve | MPU | Magnetic Pickup |
| ASTM | American Society for Testing and Materials (ASTM International) | NC | Normally Closed |
| ATS | Automatic Transfer Switch | NC | Not Connected |
| AVR | Automatic Voltage Regulator | NFPA | National Fire Protection Agency |
| AWG | American Wire Gauge | NO | Normally Open |
| CAN | Controlled Area Network | NWF | Network Failure |
| CB | Circuit Breaker | OEM | Original Equipment Manufacturer |
| CE | Conformité Européenne | OOR | Out Of Range |
| CCA | Cold Cranking Ampere | OORH/ ORH | Out Of Range High |
| CFM | Cubic Feet per Minute | OORL/ORL | Out Of Range Low |
| CGT | Cummins Generator Technologies | PB | Push Button |
| CMM | Cubic Meters per Minute | PCC | PowerCommand® Control |

| Abbr. | Description | Abbr. | Description |
|--------------|--|--------------|--------------------------------------|
| CT | Current Transformer | PGI | Power Generation Interface |
| DC | Direct Current | PGN | Parameter Group Number |
| DEF | Diesel Exhaust Fluid | PI | Proportional/Integral |
| DPF | Diesel Particulate Filter | PID | Proportional/Integral/ Derivative |
| EBS | Excitation Boost System | PLC | Programmable Logic Controller |
| ECM | Engine Control Module | PMG | Permanent Magnet Generator |
| ECS | Engine Control System | PPE | Personal Protective Equipment |
| EMI | Electromagnetic Interference | PT | Potential Transformer |
| EN | European Standard | PTC | Power Transfer Control |
| EPS | Engine Protection System | PWM | Pulse-Width Modulation |
| E-Stop | Emergency Stop | RFI | Radio Frequency Interference |
| FAE | Full Authority Electronic | RH | Relative Humidity |
| FMI | Failure Mode Identifier | RMS | Remote Monitoring System |
| FSO | Fuel Shutoff | RMS | Root Mean Square |
| Genset | Generator Set | RTU | Remote Terminal Unit |
| GCP | Generator Control Panel | SAE | Society of Automotive Engineers |
| GND | Ground | scfh | Standard Cubic Feet of gas per Hour |
| HMI | Human-Machine Interface | SCR | Selective Catalytic Reduction |
| IC | Integrated Circuit | SPN | Suspect Parameter Number |
| ISO | International Organization for Standardization | SW_B+ | Switched B+ |
| LBNG | Lean-Burn Natural Gas | UL | Underwriters Laboratories |

| Abbr. | Description | Abbr. | Description |
|-------|-------------------------|-------|------------------------------|
| LCD | Liquid Crystal Display | UPS | Uninterruptible Power Supply |
| LCT | Low Coolant Temperature | | |

2.4 Related Literature

Before any attempt is made to operate the generator set, the operator should take time to read all of the manuals supplied with the generator set and familiarize themselves with the warnings and operating procedures.

A generator set must be operated and maintained properly if you are to expect safe and reliable operation. The Operator manual includes a maintenance schedule and a troubleshooting guide. The Health and Safety manual must be read in conjunction with the Operator manual for the safe operation of the generator set.

The following documents are shipped with the generator set:

- Installation Manual for QSB5 Engine with PC 1.1/2.3 Control (A055H194)
- Operator Manual for QSB5 Engine with PC 1.1 Control (A061C651)
- Health and Safety Manual (A007W058 [0908-0110-00])
- Warranty Administration Manual (4021290)
- Global Commercial Warranty Statement (A028U870)
- All Engines Worldwide Generator Drive Warranty (EPA warranty statement) (A056N379 [3381307])

The relevant manuals appropriate to your generator set are also available; the documents below are in English:

- Generator Set Service Manual for QSB5 Engine with PC 1.1 Control (A061C653)
- Generator Set Service Manual for QSB5 Engine with PC 2.3 Control (A055H196)
- Controller Owners Manual for PowerCommand 1302 (0900-0661)
- Controller Service Manual for PowerCommand 2.3 Controller (A030F082 [0900-0666])
- Engine Operation and Maintenance Manual (4021531)
- Recommended Spares List (RSL) for each model:
 - C50D6C (A054H261)
 - C60D6C (A054H263)
 - C80D6C (A054H265)
 - C100D6C (A055J379)
 - C125D6C (A055J386)

- Parts Manual for QSB5 Engine with PC 1.1/2.3 Control (A055J388)
- InPower User Manual (0901-0108)
- Universal Annunciator Owner Manual (0900-0301)
- Standard Repair Times - AO Family (A055J390)
- Service Tool Manual (A043D529)
- Failure Code Manual (F1115C)
- Engineering Application Manual *T-030: Liquid Cooled Generator Sets* (A040S369)

2.5 Model Specifications

TABLE 1. MODEL VARIATIONS (ALL MODELS 60 HZ)

| Model | kW | Phase | Amps | Voltage (L-N/L-L) V |
|--------|----|-------|------|---------------------|
| C50D6C | 50 | 3 | 173 | 120/208 |
| | | 3 | 164 | 127/220 |
| | | 3 | 150 | 120/240 |
| | | 3 | 75 | 277/480 |
| | | 3 | 60 | 347/600 |
| | | 1 | 208 | 120/240 |
| C60D6C | 60 | 3 | 208 | 120/208 |
| | | 3 | 197 | 127/220 |
| | | 3 | 180 | 120/240 |
| | | 3 | 90 | 277/480 |
| | | 3 | 72 | 347/600 |
| | | 1 | 250 | 120/240 |
| C80D6C | 80 | 3 | 278 | 120/208 |
| | | 3 | 262 | 127/220 |
| | | 3 | 241 | 120/240 |
| | | 3 | 120 | 277/480 |
| | | 3 | 96 | 347/600 |
| | | 1 | 333 | 120/240 |

| Model | kW | Phase | Amps | Voltage (L-N/L-L) V |
|---------|-----|-------|------|---------------------|
| C100D6C | 100 | 3 | 347 | 120/208 |
| | | 3 | 328 | 127/220 |
| | | 3 | 301 | 120/240 |
| | | 3 | 150 | 277/480 |
| | | 3 | 120 | 347/600 |
| | | 1 | 417 | 120/240 |
| C125D6C | 125 | 3 | 434 | 120/208 |
| | | 3 | 410 | 127/220 |
| | | 3 | 376 | 120/240 |
| | | 3 | 188 | 277/480 |
| | | 3 | 150 | 347/600 |
| | | 1 | 521 | 120/240 |

TABLE 2. COLD WEATHER SPECIFICATIONS (ALL MODELS)

| Temperature | Description | Battery Type | Group |
|---------------------------|--|--------------|-------|
| Above 10 °C (50 °F) | No starting aids required. | Standard | 34 |
| -17 to 10 °C (0 to 50 °F) | All starting aids (battery heater, 1000 W coolant heater, battery charger) recommended. Factory options available. | 2 Standard | 34 |
| Below -17 °C (0 °F) | All starting aids (battery heater, 1500 W coolant heater, battery charger) recommended. Factory options available. | 2 Standard | 34 |

NOTICE

For NFPA 110 applications, a coolant heater is required. A factory option is available.

TABLE 3. FUEL SPECIFICATIONS (PER HOUR)

| Full Load Rating | C50D6C | C60D6C | C80D6C | C100D6C | C125D6C |
|------------------|----------|----------|----------|----------|-----------|
| Standby | 20.06 L | 23.09 L | 27.63 L | 33.69 L | 38.99 L |
| | 5.30 gal | 6.10 gal | 7.30 gal | 8.90 gal | 10.30 gal |
| Prime | 17.79 L | 20.82 L | 26.87 L | 29.15 L | 35.20 L |
| | 4.70 gal | 5.50 gal | 7.10 gal | 7.70 gal | 9.30 gal |

TABLE 4. FUEL TANK PART NUMBERS

| Option | Tank Type | Capacity Min. (Hr) | C50 D6 | C60 D6 | C80 D6 | C100 D6 | C125 D6 |
|--------|-----------|--------------------|----------|----------|----------|----------|----------|
| C301-2 | Regional | 24 | A053L909 | A053L909 | A053L909 | A053L909 | A053L909 |
| C303-2 | Regional | 48 | A053L911 | A053L911 | A053L911 | A053L911 | A053L912 |
| C305-2 | Regional | 72 | A053L911 | A053L912 | A053L912 | A053L912 | - |
| C307-2 | Regional | 96 | A053L912 | A053L912 | - | - | - |
| C319-2 | Basic | 24 | A053H409 | A053H409 | A053H409 | A053H409 | A053H409 |
| C320-2 | Basic | 48 | A053H409 | A053H411 | A053H411 | A053H412 | A053H412 |

TABLE 5. ENGINE SPECIFICATIONS (ALL MODELS)

| Type | Specification |
|-------------------|--|
| Engine | 4 Cylinder-in-line, liquid-cooled, 4-stroke <ul style="list-style-type: none"> • QSB5-G5: C50D6C (Spec A), C60D6C (Spec A), C80D6C (Spec A), and C100D6C (Spec A) • QSB5-G6: C125D6C only • QSB5-G13: C50D6C (Spec B), C60D6C (Spec B), C80D6C (Spec B), and C100D6C (Spec B) |
| Aspiration | Turbocharged and charge air cooled |
| Displacement | 4500 cc (272 in ³) |
| Compression Ratio | 17.3:1 |
| Fuel | ASTM number 2D fuel (refer to the engine operator and maintenance manual) |
| Coolant | 50/50 coolant solution (50% pure water and 50% anti-freeze) |
| Coolant Fill Rate | Maximum 3 GPM |

| Type | Specification |
|-----------|---|
| Fuel Flow | Maximum fuel flow: <ul style="list-style-type: none"> • C50D6C, C60D6C, C80D6C, and C100D6C: 133 L/hr (35 gal/hr) • C125D6C only: 95 L/hr (25 gal/hr) |
| | Maximum fuel inlet restriction with clean filter: 17 kPa (5 in. Hg) |
| | Maximum return restriction: 20 kPa (6 in. Hg) |

TABLE 6. LUBRICATING OIL SYSTEM SPECIFICATIONS (ALL MODELS)

| Type | Value |
|---|--|
| Lubricating Oil Pressure at Rated Speed (Minimum) | G5 engine: 310 kPa (45 psi) G6 engine: 344.7 kPa (50 psi) G13 engine: 276 kPa (40 psi) |
| Oil Recommendation | 15W40 (refer to the engine operator and maintenance manual) |
| Lubricating Oil Capacity: | |
| --Full at High Mark on Dipstick | 11.0 L (11.6 qt) |
| --Low Mark on Dipstick | 9 L (9.5 qt) |

TABLE 7. GENERATOR SET SIZE (ALL MODELS) (L X W X H)

| Enclosure Type | in | mm |
|---|---------------|--------------------|
| Open/Weather (Short) (does not include exhaust discharge elbow) | 98 x 40 x 58 | 2489 x 1016 x 1473 |
| Sound Level 1 (Long) | 119 x 40 x 58 | 3023 x 1016 x 1473 |
| Sound Level 2 (Long) | 136 x 40 x 58 | 3454 x 1016 x 1473 |

TABLE 8. GENERATOR SET WET WEIGHT (INCLUDING BATTERY)

| Model | kg | lb |
|----------------|------|------|
| C50D6C, C60D6C | 998 | 2200 |
| C80D6C | 1044 | 2300 |
| C100D6C | 1089 | 2400 |
| C125D6C | 1180 | 2600 |

TABLE 9. ALTERNATOR SPECIFICATIONS 60 HZ, 1800 RPM

| | C50D6C | C60D6C | C80D6C | C100D6C | C125D6C |
|---|--|---------------|---------------|----------------|----------------|
| Alternator | Brushless, 4-pole rotating field, single bearing | | | | |
| Power (kVA) 1Phase/3 Phase - Standby | 50/62.5 | 60/75 | 80/100 | 100/125 | 125/156 |
| Power (kVA) 1Phase/3 Phase - Prime | 45/56 | 55/69 | 72/90 | 90/112.5 | 113/141 |
| Rated Voltages (V) (Line to Neutral/Line to Line) | 120/240 | | | | |
| | 120/208 | | | | |
| | 127/220 | | | | |
| | 277/480 | | | | |
| | 347/600 | | | | |

NOTICE**Maximum I₂ = 8%.**

TABLE 10. GENERATOR SET DERATING GUIDELINES (STANDBY)

| Model | Spec | Above | Derate At (per 10 °C/18° F) | Above | Derate At (per 300 m/1000 ft) | Until | Derate At (per 300 m/1000 ft) | | |
|---------|------|-------|-----------------------------------|----------------------|-------------------------------------|-------|-------------------------------------|---------------------|-------|
| C50D6C | A | 40 °C | 19% | 2012 m (6600 ft) | 17% | x | | | |
| C60D6C | A | | | 1890 m (6200 ft) | | | | | |
| C80D6C | A | | | 1585 m (5200 ft) | | | | | |
| C100D6C | A | | | 1280 m (4200 ft) | | | | | |
| C125D6C | A | | | 1097 m (3600 ft) | | | | | |
| C50D6C | B | | 16.10% | 4648 m (15250 ft) | 2.20% | | | | |
| C60D6C | B | | | 3581 m (11750 ft) | | | | | |
| C80D6C | B | | | 1524 m (5000 ft) | 17.50% | | | 1707 m (5600 ft) | 2.20% |
| C100D6C | B | | | 1295 m (4250 ft) | | | | | |

TABLE 11. GENERATOR SET DERATING GUIDELINES (PRIME)

| Model | Spec | Above | Derate At (per 10 °C/18° F) | Above | Derate At (per 300 m/1000 ft) | Until | Derate At (per 300 m/1000 ft) |
|---------|------|--------|-----------------------------------|----------------------|-------------------------------------|-------|-------------------------------------|
| C50D6C | A | 40 °C | 19% | 2073 m (6800 ft) | 17% | x | |
| C60D6C | A | | | 1951 m (6400 ft) | | | |
| C80D6C | A | | | 1707 m (5600 ft) | | | |
| C100D6C | A | | | 1463 m (4800 ft) | | | |
| C125D6C | A | | | 1158 m (3800 ft) | | | |
| C50D6C | B | 16.10% | | 5258 m (17250 ft) | 2.30% | | |
| C60D6C | B | | | 4343 m (14250 ft) | | | |
| C80D6C | B | | | 1753 m (5750 ft) | | | |
| C100D6C | B | | | 1448 m (4750 ft) | 17.50 % | | |

TABLE 12. CONTROL SPECIFICATIONS (ALL MODELS)

| Control |
|-------------------|
| PowerCommand® 1.1 |
| PowerCommand® 2.3 |

TABLE 13. DC SYSTEM SPECIFICATIONS (ALL MODELS)

| Type | Value |
|-------------------------------|---|
| Nominal Battery Voltage (VDC) | 12 |
| Battery Group | 34 |
| Battery Type | Lead acid (wet) |
| Minimum Cold Crank Amps (CCA) | 2 batteries x 850 CCA (per battery) = Total 1700 CCA |

2.6 After Sales Services

Cummins offers a full range of maintenance and warranty services.

Maintenance

⚠ WARNING

Electrical Generating Equipment

Incorrect service or parts replacement can result in severe personal injury, death, and/or equipment damage.

Make sure service personnel are qualified to perform electrical and mechanical service.

For expert generator set service at regular intervals, contact your Cummins Inc. service provider. See power.cummins.com/sales-service-locator for service locations that service this application. Maintenance tasks should only be undertaken by trained and experienced technicians provided by your Cummins Inc. service provider.

Warranty

For details of the warranty coverage for your generator set, refer to the *Warranty Statement* listed in the Related Literature section.

Extended warranty coverage is also available. In the event of a breakdown, prompt assistance can normally be given by factory trained service technicians with facilities to undertake all minor and many major repairs to equipment on site.

For further warranty details, contact your authorized dealer.

NOTICE

Damage caused by failure to follow the manufacturer's recommendations will not be covered by the warranty. Please contact your authorized dealer.

Warranty Limitations

For details of the warranty limitations for your generator set, refer to the warranty statement applicable to the generator set.

How to Obtain Service

For parts, service, and product information, contact the nearest authorized Cummins Inc. dealer. To easily locate the nearest certified distributor/dealer for Cummins generator sets in your area, or for more information, contact us at 1-800-CUMMINS™ (1-800-286-6467) or visit www.cummins.com/support.

Generator Set Nameplate

WARNING

Electrical Generating Equipment

Improper service or replacement of parts can lead to severe personal injury or death and to damage to equipment and property.

Make sure service personnel are qualified to perform electrical and mechanical service.

NOTICE

Unauthorized modifications or replacement of fuel, exhaust, air intake or speed control system components that affect engine emissions are prohibited by law in the State of California.

Model, Spec, and Serial Numbers: Be ready to provide the model, spec, and serial numbers on the generator set nameplate when contacting Cummins Inc. for information, parts, and service. The nameplate is located on the inside of the customer access door on enclosed generator sets.

Record these numbers so that they are easy to find when needed. Each character in these numbers is significant for obtaining the right parts listed in the Parts Catalog. Genuine Cummins Inc. replacement parts are recommended for best results.

My Generator Set Information

| | |
|---------------|--|
| Model | |
| Spec | |
| Serial Number | |

Manufacturing Facilities

| Facility | Address | Phone Numbers |
|--------------------|---|--|
| U.S. and CANADA | Cummins Inc. 1400 73rd Ave. NE Minneapolis, MN 55432 USA | Toll Free 1-800-CUMMINS™ (1-800-286-6467) Phone +1 763-574-5000 Fax +1 763-574-5298 |
| EMEA, CIS | Cummins Inc. Columbus Avenue Manston Park Manston, Ramsgate Kent CT12 5BF United Kingdom ----- Cummins Inc. Royal Oak Way South Daventry Northamptonshire NN11 8NU United Kingdom | Phone +44 1843 255000 Fax +44 1843 255902 |
| ASIA PACIFIC | Cummins Inc. 10 Toh Guan Road #07-01 TT International Tradepark Singapore 608838 | Phone +65 6417 2388 Fax +65 6417 2399 |
| BRAZIL | Rua Jati, 310, Cumbica Guarulhos, SP 07180-900 Brazil | Phone +55 11 2186 4195 Fax +55 11 2186 4729 |
| CHINA | Cummins Inc. 2 Rongchang East Street, Beijing Economic – Technological Development Area Beijing 100176, P.R. China | Phone 86 10 59023001 Fax +86 10 5902 3199 |
| INDIA | Cummins Inc. Plot No B-2, SEZ Industrial Area, Village-Nandal & Surwadi, Taluka- Phaltan Dist- Satara, Maharashtra 415523 India | Phone +91 021 66305514 |
| LATIN AMERICA | 3350 Southwest 148th Ave. Suite 205 Miramar, FL 33027 USA | Phone +1 954 431 551 Fax +1 954 433 5797 |

| Facility | Address | Phone Numbers |
|-----------------|--|--|
| MEXICO | Eje 122 No. 200 Zona Industrial San Luis Potosi, S.L.P. 78395 Mexico | Phone +52 444 870 6700 Fax +52 444 824 0082 |

This page is intentionally blank.

3 Control System - PowerCommand 1.1

3.1 Control System Description

The control system is used to start and stop the generator set, and provides full generator set monitoring capability and protection from the display screen. It monitors the engine for temperature, oil pressure, and speed. It also provides voltage and current metering. In the event of a fault, the unit will indicate the fault type and, on critical faults, automatically shut down the generator set.

All indicators, control buttons, and the display screen are on the face of the operator panel.

There are two fault level signals generated by the control system:

- **Warning:** Signals an imminent or non-critical fault for the generator set. The control provides an indication only for this condition.
- **Shutdown:** Signals a potentially critical fault for the generator set. The control will immediately take the engine off-load and automatically shuts it down.

The standard control system operates on 12 VDC battery power. The history data is stored in non-volatile memory and will not be deleted due to the loss of battery power.

Operator Panel

[Figure 1 on page 28](#) shows the features of the front panel. It includes six LED indicators, the graphical display, and six buttons used to navigate through the menus and adjust parameters.

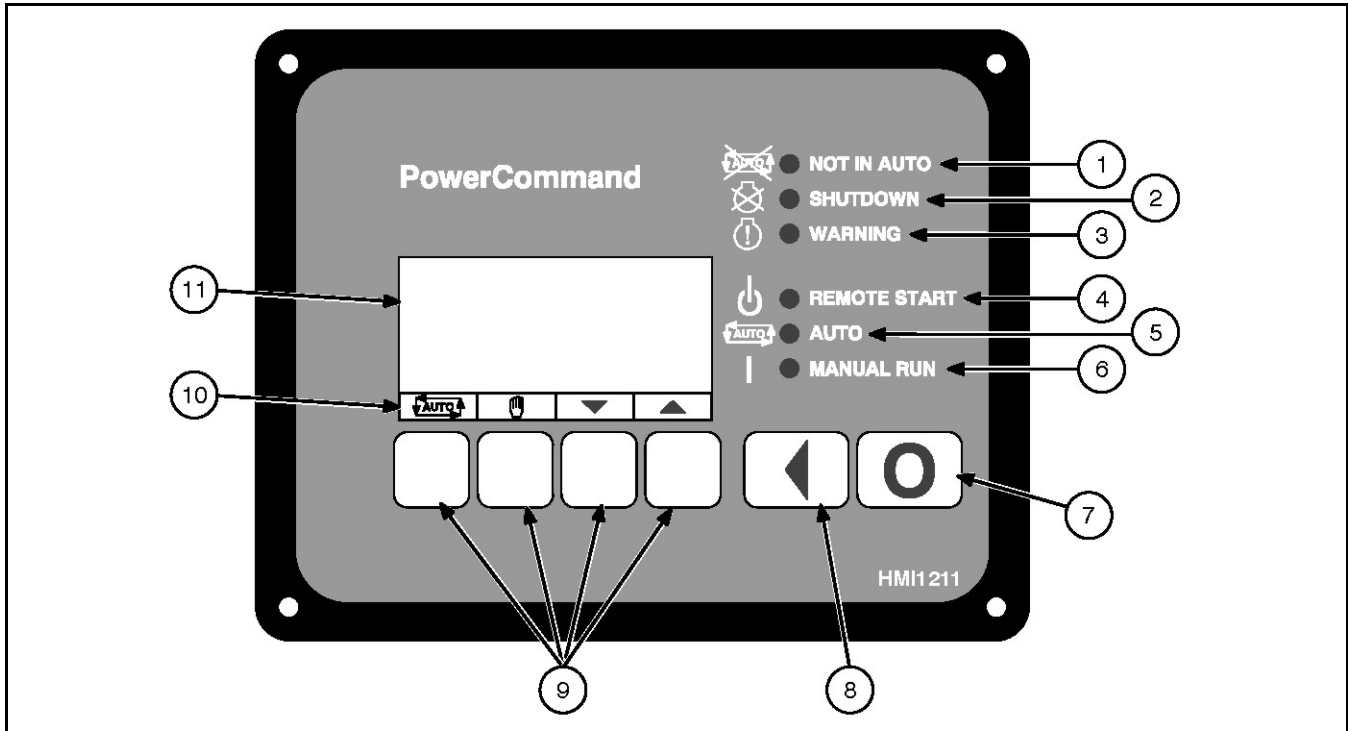

| No. | Description | No. | Description |
|-----|------------------------------|-----|---|
| 1 | LED Indicator – Not in Auto | 7 | Generator Set Off Mode Button |
| 2 | LED Indicator – Shutdown | 8 | Previous Screen Button |
| 3 | LED Indicator – Warning | 9 | Selection Buttons (four) (for use with Item 10) |
| 4 | LED Indicator – Remote Start | 10 | Menu Bar (provision for four symbols) |
| 5 | LED Indicator – Auto | 11 | Graphical LCD Display |
| 6 | LED Indicator – Manual Run | | |

FIGURE 1. OPERATOR PANEL

In-Home Operator Panel (Accessory)

The in-home operator panel is an optional display that may be purchased. This panel is intended to serve as a convenience option to the standard operator panel mounted on the generator set.

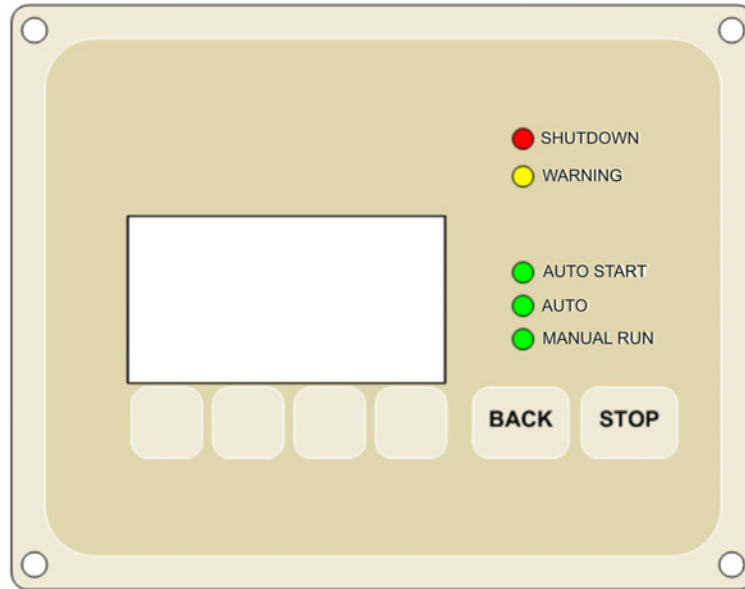

FIGURE 2. IN-HOME OPERATOR PANEL









Display Text or Symbolic Version

The operator panel graphical display can be set to show text (English only) or symbols for fault messages, operator menus, and the Mode Change Menu. Descriptions of commonly used symbols are included in the following table. Combinations of symbols are used to display some fault conditions.

When shipped from the factory, the display is set to display symbols. Qualified service personnel are required to change the default setting.

TABLE 14. SYMBOLS

| Symbol | Text |
|-----------|-----------------------------------|
| | Generator Warning Fault |
| | Generator Shutdown Fault |
| | Coolant Temperature |
| | Oil Pressure |
| | Voltage Alternating Current (VAC) |
| | Voltage Direct Current (VDC) |
| | AC Current |
| Hz | Frequency |

| Symbol | Text |
|---|------------------|
|  | Battery |
|  | Out of Range |
|  | High or Pre-High |
|  | Low or Pre-Low |
|  | Annunciator |
|  | Over Speed |
|  | Crank Fail |
|  | Emergency Stop |

LED Indicators

[Figure 1 on page 28](#) shows the front panel of the Operator Panel. It includes six LED indicators, the graphical display and six buttons used to navigate through the menus and adjust parameters.

Not in Auto

This red lamp is lit when the control is NOT in Auto.

Shutdown Status

This red lamp is lit when the control detects a Shutdown condition. The generator set cannot be started when this lamp is on. After the condition has been corrected, the lamp can be reset by pressing the Off button.

Warning

This amber lamp is lit whenever the control detects a Warning condition. This lamp is automatically shut off when the Warning condition no longer exists.

Remote Start

This green lamp indicates the control is receiving a **remote run** signal.

Auto

This green lamp indicates that the control is in Auto mode. Auto mode can be selected by pressing the  selection button from any of the Operator menus.

Manual Run |

This green lamp indicates that the control is in the Manual Run mode. Manual Run can be selected by pressing the  selection button from any of the Operator menus.





Default Settings

The Operator Panel can display SAE or Metric units of measurement and should be set during the initial setup of the generator set. Only trained and experienced personnel are allowed to change the default setting. Contact your authorized dealer.

Display Menu Selection Buttons



Four momentary soft-key buttons are used to step through the various menus and to adjust parameters. These selection buttons are "active" when a word or symbol in the graphical display is shown above the button. Some submenus do not include any active buttons.

The function of the four selection buttons varies with each menu.

- When the  symbol is displayed, the selection button can be used to switch to Auto mode.
- When the  symbol is displayed, the selection button can be used to switch to Manual Run mode.
- When the up and down triangles ( and ) are displayed, the selection buttons are used to navigate between a series of submenus.

NOTICE

When any Operator menu is displayed, a series of Service menus can be viewed by simultaneously pressing the  and  selection buttons for two seconds.

- When a  symbol is displayed, the selection button can be used to abort the Auto or Manual Run mode and return to the Operator menu that was displayed before the Auto or Manual Run mode was selected.
- When **ADJUST** is displayed, the selection button is used to display an adjustable menu. When the **ADJUST** button is pressed, the first adjustable parameter or value in the submenu is highlighted.
- When the  symbol is displayed, the selection button is used to navigate to an editable field within a menu.
- When the **+** and **-** symbols are displayed, the selection buttons are used to increase or decrease a parameter or value shown on the screen.

When changing values, pressing the button below the **+** symbol increase the value and pressing the button below the **-** symbol decreases the value.

- When **SAVE** is displayed, the selection button is used to save changes made in a submenu. **If the Previous Menu button is pressed before pressing SAVE, the changes are not saved.**
- Some menus include a list of numbered subjects. These menus include numbers in parenthesis (for example, (1)) displayed above the selection buttons. The selection buttons are then used to display submenus of the subjects included in the list.
- When a black box ████ is displayed, the selection button has no function.

Control Buttons

The figure below illustrates the six control buttons - four selection buttons, the **Previous Menu** button, and the **Off** button.

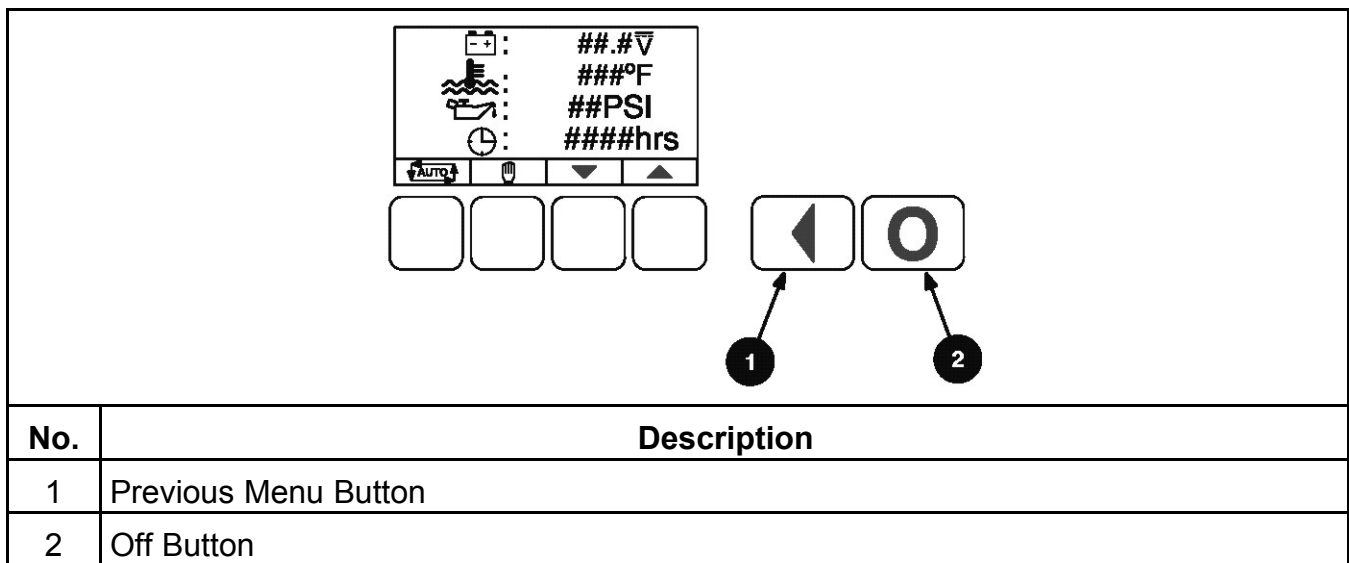



FIGURE 3. CONTROL BUTTONS

Previous Main Menu Button

Press the  button to view the previous main menu.

| |
|--|
| NOTICE |
| In the Screen Adjust menu, settings are not saved when the  button is pressed. |

The  button is also used to acknowledge warning and shutdown messages after the fault has been corrected. Pressing this button clears the fault from the front panel display and the previous menu is redisplayed.

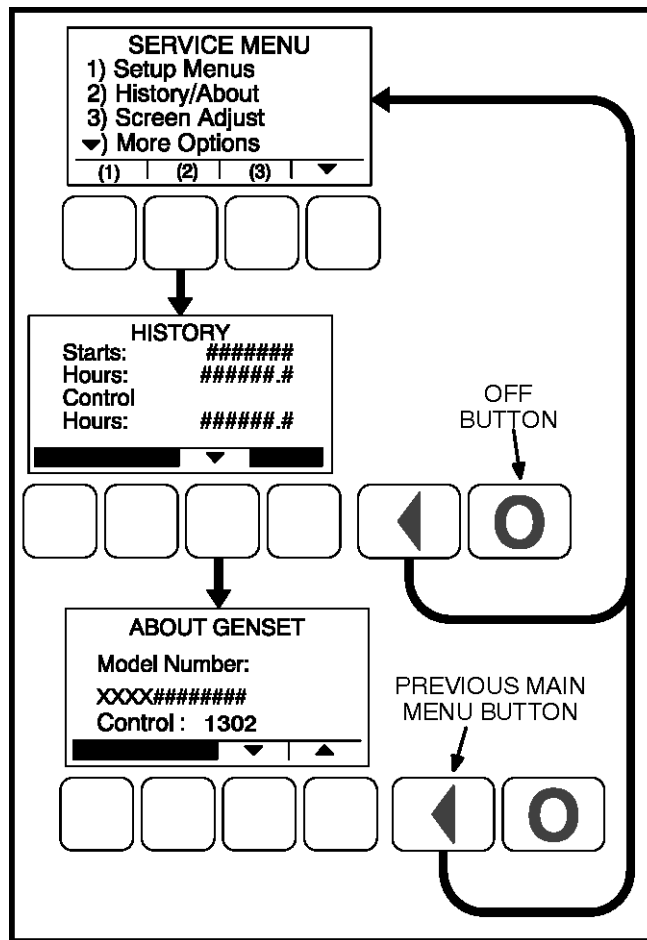

FIGURE 4. PREVIOUS MAIN MENU AND OFF BUTTONS

Off Button 

Press this button to switch to Off mode. Off mode disables the control's Auto or Manual Run modes. Pressing the **Off** button resets the control.

If the **Off** button is pressed during generator set operation (manual or remote start), the engine immediately shuts down. If possible, hot shutdown under load should be avoided to help prolong the reliability of the generator set.

NOTICE

Switching to Off mode can be restricted to authorized personnel. If a control panel is set-up with the mode change access code feature enabled, an access code must first be entered before the mode can be changed.

Exercise Settings

NOTICE

When battery power is lost, these settings must be reset.

NOTICE

Not applicable without a single phase RA series transfer switch.

To access the Clock/Exerciser Menu:

1. From any Information Menu, hold down the up and down arrows simultaneously for two seconds. The Service Menu appears.
2. Navigate through the screens to find and select **Clock/Excr** in the Service Menu.

NOTICE

The following screens represent the standard operator panel (that is, HMI211). If using an in-home operator panel, which may be additionally purchased as an option, the screens may look slightly different. This procedure applies to both operator panels.

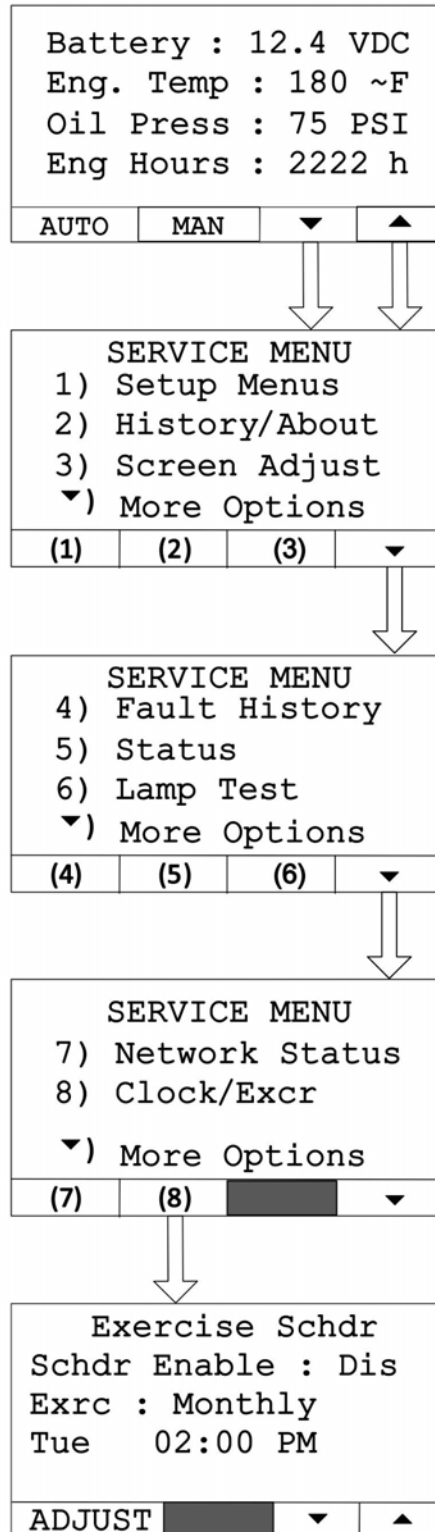

**FIGURE 5. CLOCK/EXERCISER MENU NAVIGATION
Updating Exercise Frequency (1-Phase ATS)**

NOTICE**Not applicable without a single phase RA series transfer switch.**

To update the exercise frequency and dates on the Clock/Exerciser Menu:

1. From any Information Menu, hold down the up and down arrows simultaneously for two seconds. The Service Menu appears.
2. Access the Time Setup screen by selecting **Clock Exerciser** on the Genset Service Menu.
3. Press the down key on the Time Setup screen to access the Daylight Saving Adjust screen.
4. Select **Adjust**.
5. Press the down key on the Daylight Saving Adjust Start screen.
6. Select **Adjust**.
7. Press **Exercise Schdr** on the Daylight Saving Adjust End screen.
8. Press **Adjust**.

When updating these settings, the functions of the keys are as follows:

- The horizontal right arrow key is used to select successive blocks for editing settings on the screen.
- Use the + or - keys to edit the following settings:
 - Schdr Enable: Enable or Disable
 - Exercise Schedule: Semi-Annual (every six months), Quarterly, Monthly, Bi-Monthly (the first and third week of every month based on the time set when the Bi-Monthly option is selected), or Weekly
 - Exercise Schedule: Day, Hours, Minutes, AM/PM
- Press **Save** to save any changes. After saving, the Save button changes to the Adjust button.

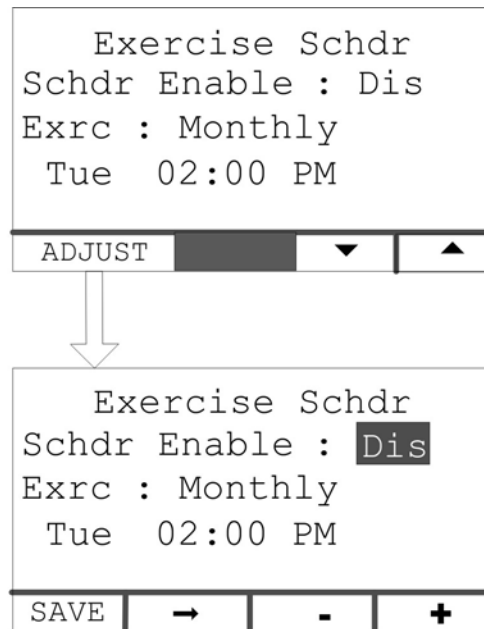

FIGURE 6. EXERCISE FREQUENCY NAVIGATION
Updating Exercise Duration (1-Phase ATS)

NOTICE

Not applicable without a single phase RA series transfer switch.

To update the exercise duration on the Clock/Exerciser Menu:

1. From any Information Menu, hold down the up and down arrows simultaneously for two seconds. The Service Menu appears.
2. Access the Time Setup screen by selecting **Clock Exerciser** on the Genset Service Menu.
3. Press the down key on the Time Setup screen to access the Daylight Saving Adjust screen.
4. Select **Adjust**.
5. Press the down key on the Daylight Saving Adjust Start screen.
6. Select **Adjust**.
7. Press **Exercise Schdr** on the Daylight Saving Adjust End screen.
8. Press the down key on the Exercise Schdr Menu.
9. Press **Adjust**.

When updating these settings, the functions of the keys are as follows:

- The horizontal right arrow key is used to select the duration block for editing exercise duration.
- Use the + or - keys to edit the exercise duration minutes.

- Press **Save** to save any changes. After saving, the Save button changes to the Adjust button.

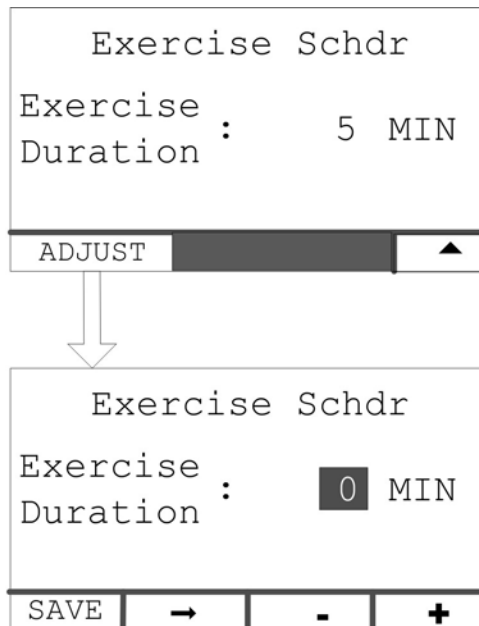

FIGURE 7. EXERCISE DURATION NAVIGATION

Time Setup (1-Phase ATS)

NOTICE

When battery power is lost, these settings must be reset.

NOTICE

Not applicable without a single phase RA series transfer switch.

To set up the generator set clock for the current date and time:

1. From any Information Menu, hold down the up and down arrows simultaneously for two seconds. The Service Menu appears.
2. Access the Time Setup screen by selecting **Clock Exerciser** on the Genset Service Menu.
3. Select **Adjust**.

When updating these settings, the functions of the keys are as follows:

- The horizontal right arrow key is used to select successive blocks for editing settings on the screen.
- Select the left arrow to return to the previous screen.
- Adjust values by using the + or - keys on the Adjust Menu of the Time Setup screen.
- Press **Save** to save any changes. After saving, the Save button changes to the Adjust button.

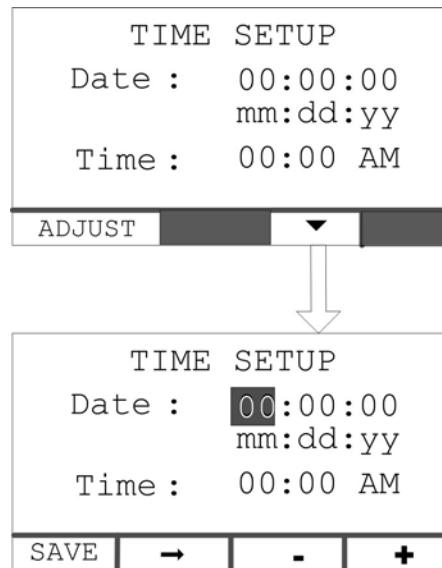

FIGURE 8. TIME SETUP SCREEN

Updating Daylight Saving Adjust Screens

Update Values on the Daylight Saving Adjust Screen

1. From any Information Menu, hold down the up and down arrows simultaneously for two seconds. The Service Menu appears.
2. Navigate to the Genset Service Menu.
3. Select **Clock Exerciser** to access the Time Setup screen.
4. Press the down key on the Time Setup screen to access the Daylight Saving Adjust screen.
5. Select **Adjust**. When updating these settings, the functions of the keys are as follows:

TABLE 15. KEY FUNCTIONS ON THE DAYLIGHT SAVING ADJUST SCREEN

| Key/Button | Function |
|----------------------------|--|
| Horizontal right arrow key | Select successive blocks for editing settings on the screen |
| Left arrow key | Return to the previous screen |
| + or - keys | Adjust values on the Adjust screen of the Daylight Saving Adjust screen |
| Save button | Save any changes; after saving, the Save button changes to the Adjust button |

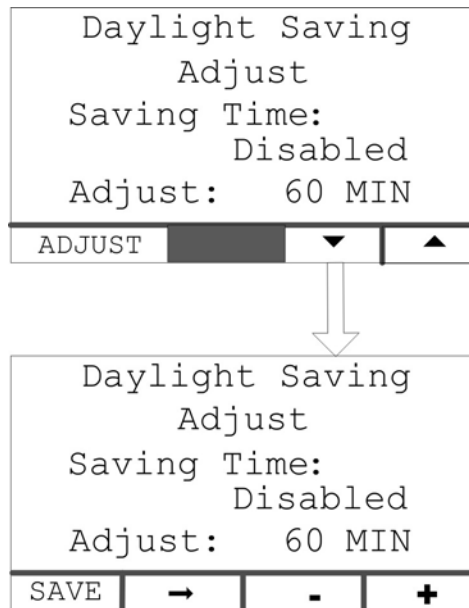

FIGURE 9. "DAYLIGHT SAVING ADJUST SAVING TIME" SCREEN NAVIGATION

Access and Update the Daylight Saving Adjust Start Screen

1. Press the down arrow key on the Daylight Saving Adjust screen.
2. Press **Adjust**. When updating these settings, the functions of the keys are as follows:

TABLE 16. KEY FUNCTIONS ON THE DAYLIGHT SAVING ADJUST START SCREEN

| Key/Button | Function |
|----------------------------|--|
| Horizontal right arrow key | Select successive blocks for editing settings on the screen |
| + or - keys | Adjust Month, Week, Day or Hour |
| Save button | Save any changes; after saving, the Save button changes to the Adjust button |

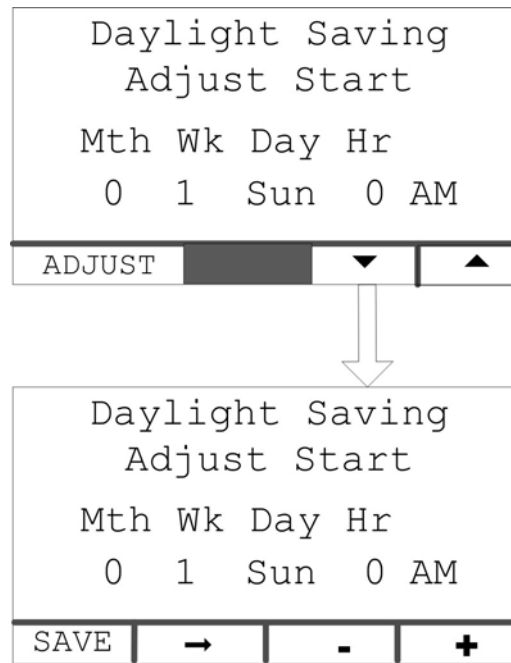

FIGURE 10. DAYLIGHT SAVING ADJUST START SCREEN

Update the Daylight Saving Adjust End Screen

1. Press the down key on the Daylight Saving Adjust Start screen.
2. Press **Adjust**. When updating these settings, the functions of the keys are as follows:

TABLE 17. KEY FUNCTIONS ON THE DAYLIGHT SAVING ADJUST END SCREEN

| Key/Button | Function |
|----------------------------|--|
| Horizontal right arrow key | Select successive blocks for editing settings on the screen |
| + or - keys | Adjust Month, Week, Day or Hour |
| Save button | Save any changes; after saving, the Save button changes to the Adjust button |

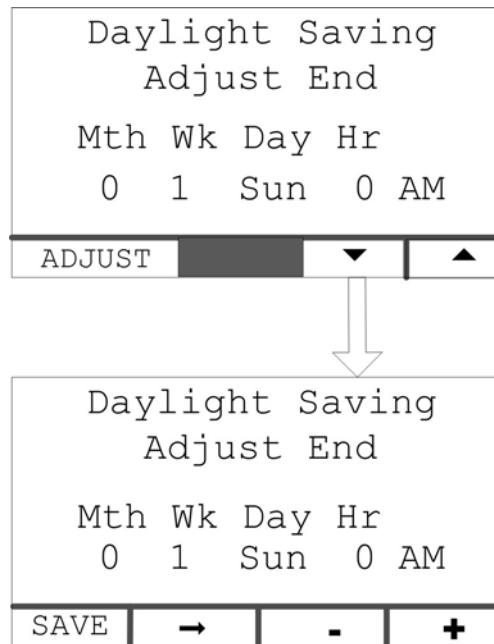

FIGURE 11. DAYLIGHT SAVING ADJUST END SCREEN

Brightness and Contrast

The Screen Adjust screen allows the contrast, brightness, and units to be set. To access the Screen Adjust screen:

1. From any Information screen, hold down the up and down arrows simultaneously for two seconds to gain access to the Service Menu screen.
2. Select **Screen Adjust**.

To adjust the contrast, brightness, or units from the Screen Adjust screen:

1. From the Screen Adjust screen, select **Adjust** to access the screen variables.
2. Press the right arrow to move between the variables.
3. Adjust settings, and press **Save** to save any changes.

When updating these settings, the functions of the keys are as follows:

- The horizontal right arrow key is used to select successive blocks for editing settings on the screen.
- Select the left arrow to return to the previous screen.
- Adjust values by using the + or - keys on the Adjust screen of the Display Setup screen.
- Press **Save** to save any changes. After saving, the Save button changes to the Adjust button.

NOTICE

The following screens represent the standard operator panel (HMI211). If using an in-home operator panel, which may be additionally purchased as an option, the screens may look slightly different. This procedure applies to both operator panels.

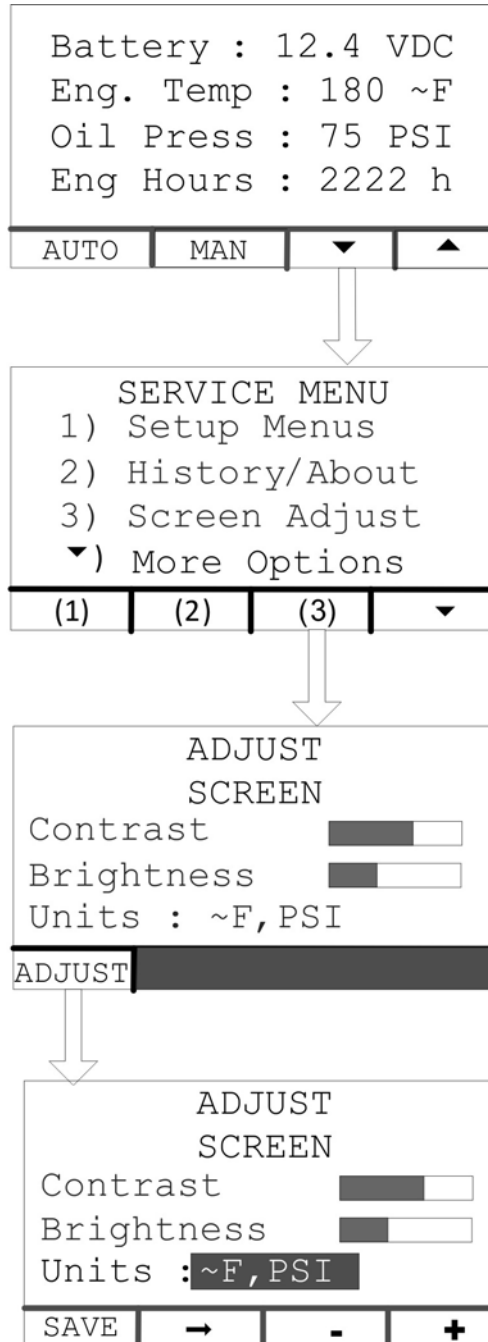

FIGURE 12. BRIGHTNESS AND CONTRAST SCREEN NAVIGATION

NOTICE

Adjusting the brightness on the operator panel adjusts the brightness of both the LCD backlight and the LEDs on the display. The contrast should never be 0 or 100% on any of the screens. The default value for Brightness is 50%.

History and About Menu

To access the History/About screen:

1. From any Information Menu, hold down the up and down arrows simultaneously for two seconds. The Service Menu appears.
2. Select **History/About**.
3. Advance through the screens to view information about the generator set, control, and display.

NOTICE

The following screens represent the standard operator panel (HMI211). If using an in-home operator panel, which may be additionally purchased as an option, the screens may look slightly different. This procedure applies to both operator panels.

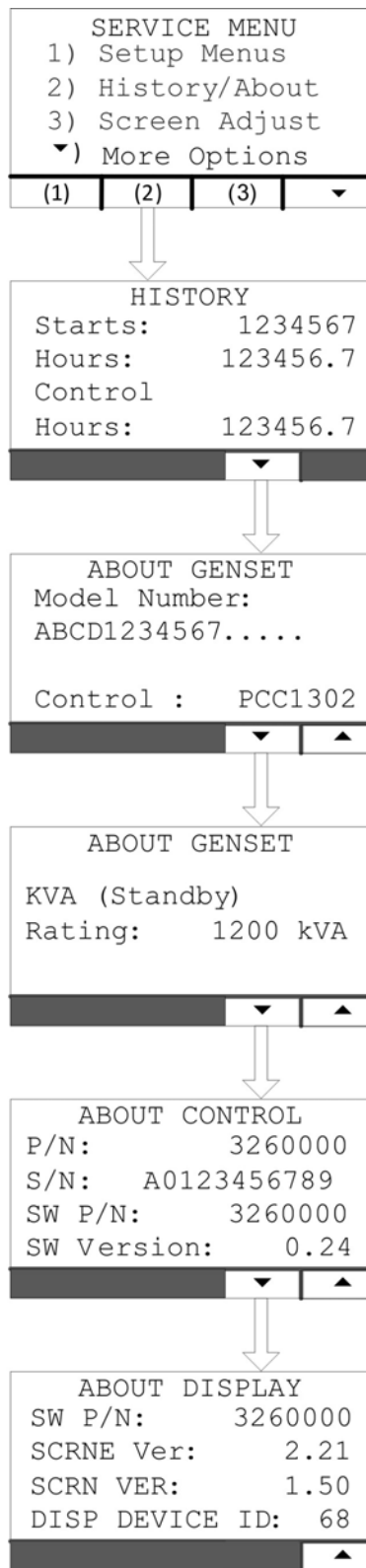

FIGURE 13. HISTORY/ABOUT MENU

Fault Log

To check the fault log:

1. From any Information Menu, hold down the up and down arrows simultaneously for two seconds. The Service Menu appears.
2. Select **Fault History**.

NOTICE

The active faults are displayed first. If there are no active faults, this screen is skipped. Following the Active Faults screen are the Fault History screens. These screens display the faults in chronological order from newest to oldest.

NOTICE

The following screens represent the standard operator panel (HMI211). If using an in-home operator panel, which may be additionally purchased as an option, the screens may look slightly different. This procedure applies to both operator panels.

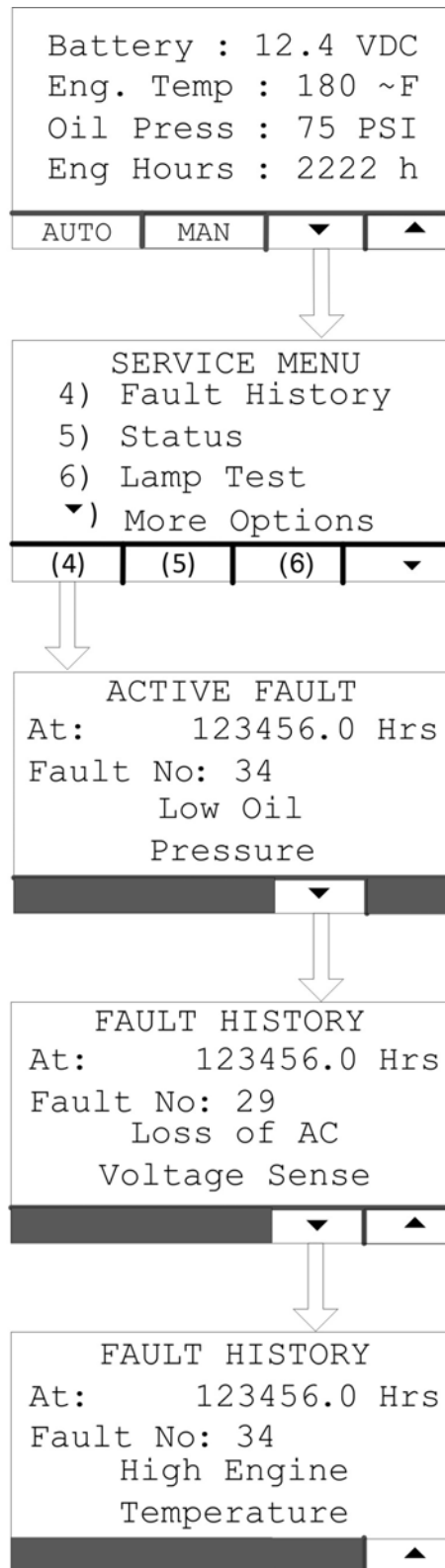

FIGURE 14. FAULT LOG SCREEN

3.2 Selecting Operating Modes





Selecting Manual Run Mode

WARNING

Electrical Generating Equipment

When changing modes, the generator set can start or stop without warning (for example, Auto Mode may have been selected with no mains (utility) power available).

Make sure there is no danger to personnel or equipment, if the generator set starts or stops when changing modes.

1. Before proceeding to change the mode, make sure that it is safe to do so.
2. Press the  Manual Run button on any of the Operator menus or the "Establishing/Re-establishing communication with control" menus.
3. If the Mode Change Access Code menu is enabled, the Mode Change Access Code is displayed. Enter the Mode Change Access Code.
4. A menu with alternating arrows is displayed above a second  symbol.
5. Press the second  Manual Run button, and the generator set will now begin the Manual start sequence. The Operator menu that was displayed before Manual Run mode was selected is re-displayed, but with the  symbol blacked out.

NOTICE

To disable Manual Run mode, press the Off button.

NOTICE

Auto mode can also be selected while in Manual Run mode. Switching to Auto mode may result in the generator set shutting down.

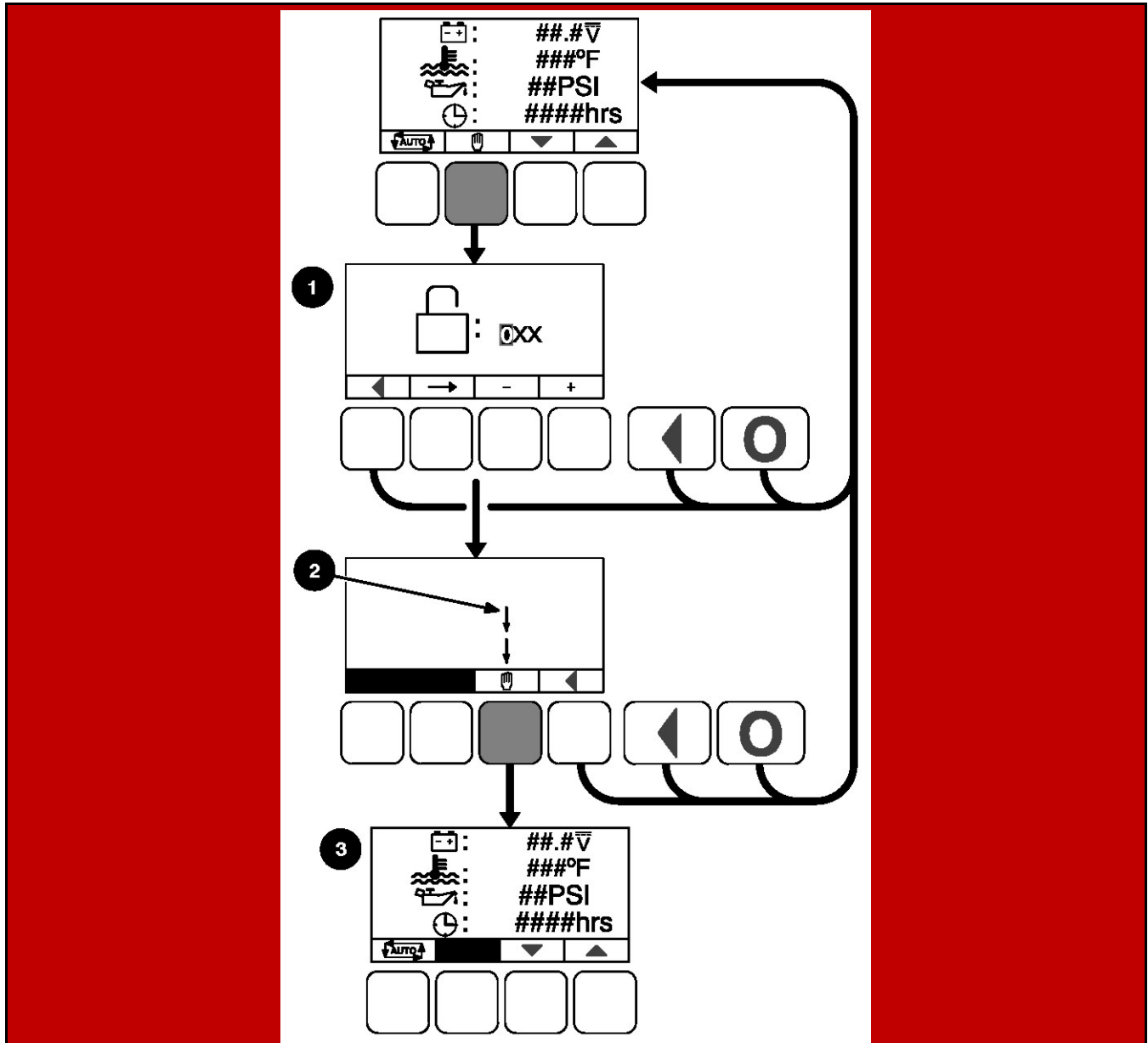

| No. | Description | No. | Description |
|-----|---|-----|--------------------------|
| 1 | Menu Displayed Only When the Mode Change Access Code Feature Is Enabled | 3 | Manual Run Mode Selected |
| 2 | Alternating Arrows Displayed | | |

FIGURE 15. SELECTING MANUAL RUN MODE

Selecting Auto Mode





WARNING

Electrical Generating Equipment

When changing modes, the generator set can start or stop without warning (for example, Auto Mode may have been selected with no mains (utility) power available).

Make sure there is no danger to personnel or equipment, if the generator set starts or stops when changing modes.

To switch to Auto mode (see [Figure 16 on page 51](#)),

1. Ensure that it is safe to do so before proceeding to change the mode.
2. Press the  Auto button on any of the Operator menus, or the 'Establishing/Re-establishing communication with control' menus.
3. If the mode change access code feature is enabled, the Mode Change Access Code menu is displayed. Enter the Mode Change Access Code.
4. A menu with alternating arrows will then be displayed above a second  Auto symbol.
5. Press this second  Auto button. The Operator menu that was displayed before Auto mode was selected is re-displayed, but with the  Auto symbols blacked out and  Manual Run symbols visible.

To disable Auto mode, press the Off button.

The generator set is now ready to receive a remote start signal that will initiate the Auto run mode.

WARNING

Should a remote start signal be received, the generator set starts automatically. Make sure there is no danger to personnel or equipment should the generator set start without warning.

NOTICE

Manual Run mode can also be selected FROM Auto mode. Switching to Manual Run mode results in the generator set starting up.

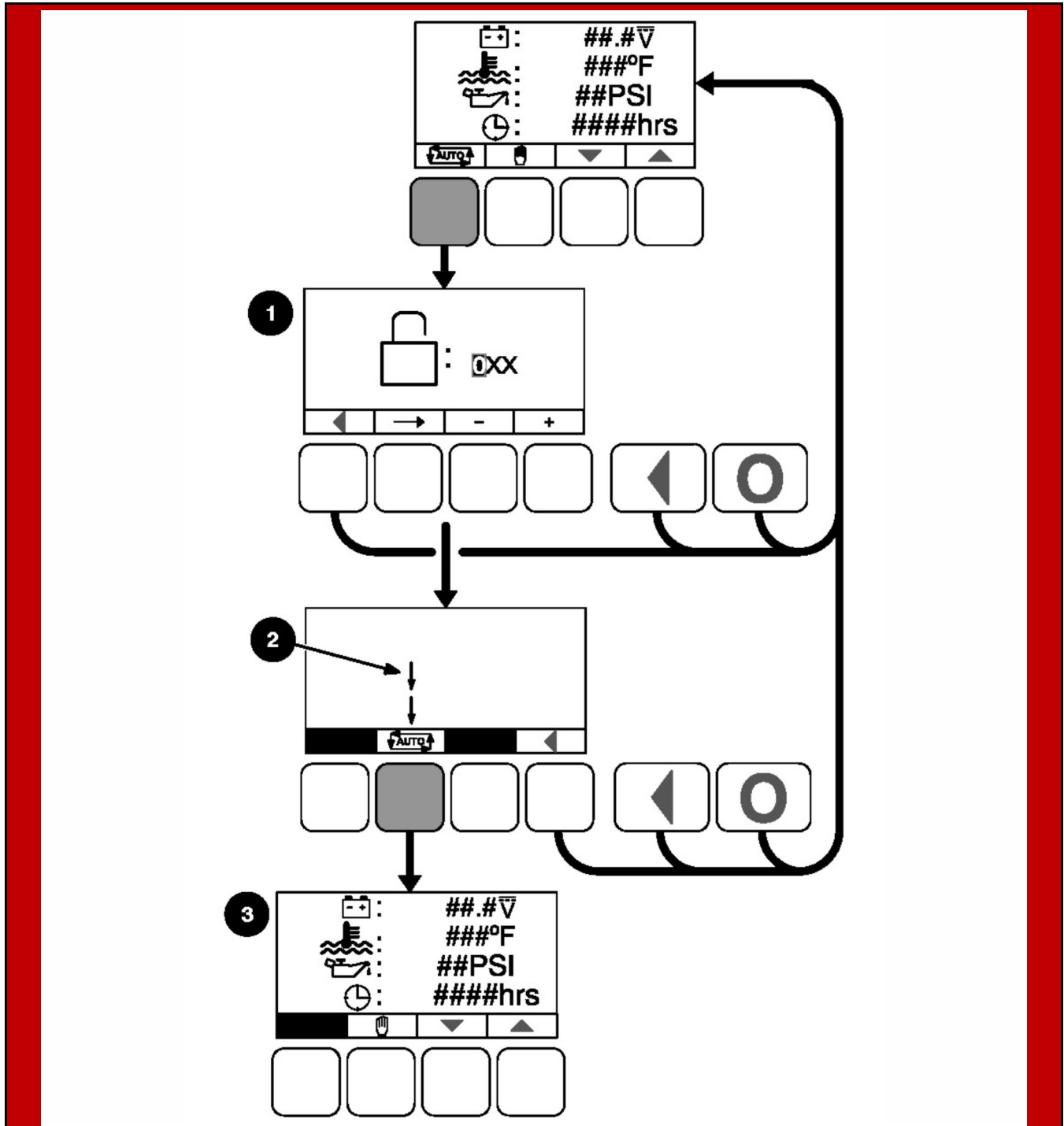

| No. | Description | No. | Description |
|-----|---|-----|--------------------|
| 1 | This Menu Is Displayed Only if the Mode Change Access Code Feature Is Enabled | 3 | Auto Mode Selected |
| 2 | Alternating Arrows Are Displayed | | |

FIGURE 16. SELECTING AUTO MODE

Selecting Off Mode

WARNING

Electrical Generating Equipment

When changing modes, the generator set can start or stop without warning (for example, Auto Mode may have been selected with no mains (utility) power available).

Make sure there is no danger to personnel or equipment, if the generator set starts or stops when changing modes.

To switch to Off mode (see the figure below),

1. Make sure that it is safe to do so before proceeding to stop the set.
2. Press the Off button on any of the Operator menus or the "Establishing/Re-establishing communication with control" menus.
3. If the Mode Change Access Code is enabled, the Mode Change Access Code will be displayed. Enter the Mode Change Access Code.
4. On entering the last correct digit, the basic screen will re-appear, and the set will stop without a Time Delay to Stop.

NOTICE

Make sure that there is no danger to personnel or equipment if the generator set is stopped.

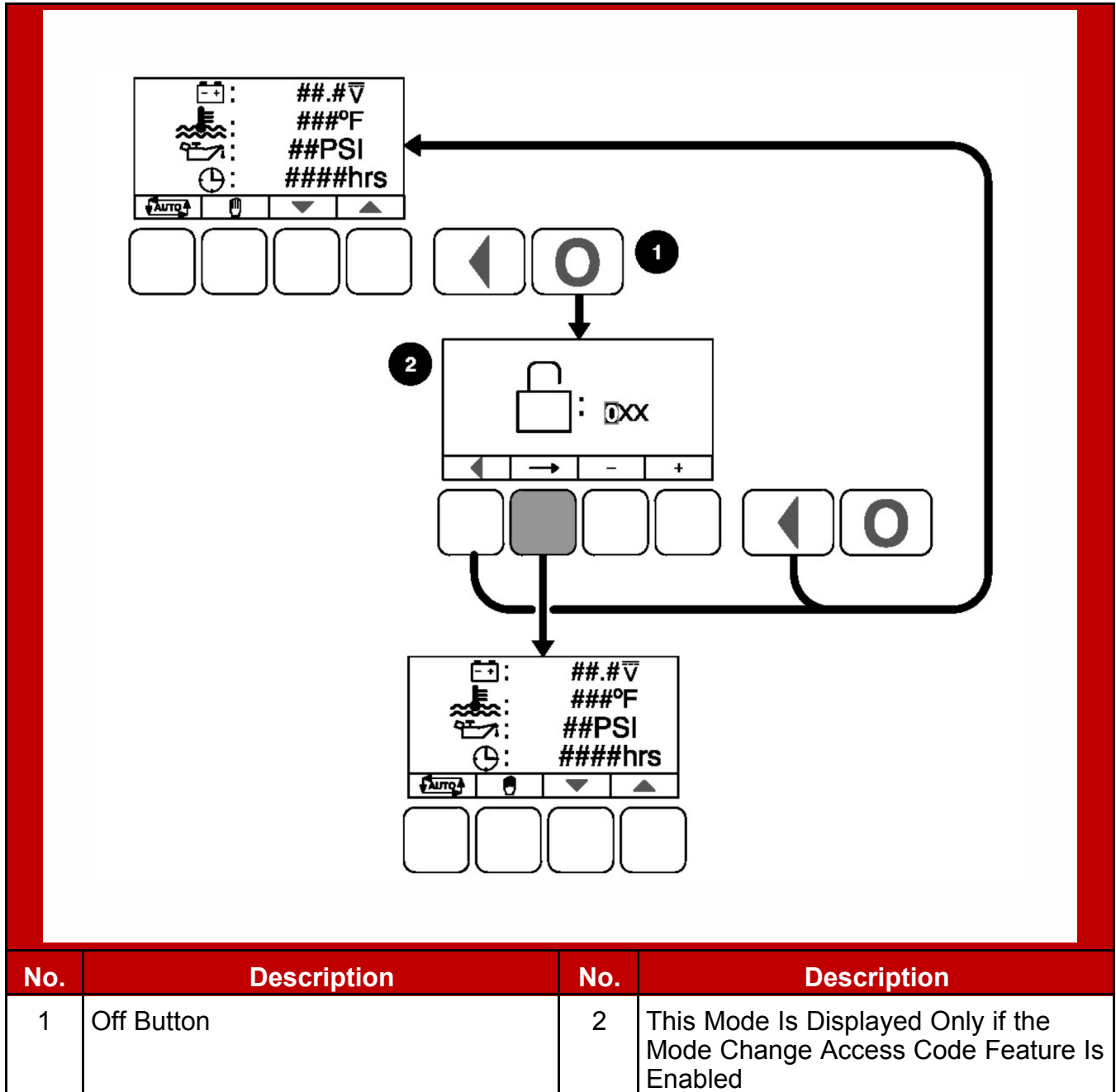

FIGURE 17. SELECTING OFF MODE

3.3 Operating Modes

The PowerCommand® control is operated by the **Manual Run**, **Off**, and **Auto** buttons on the operator panel.

Off Mode

When in the Off mode, the control does not allow the generator set to start.

If the generator set is running in either Manual Run or Auto mode and the Off button is pressed, the control immediately stops the generator set, and the control transitions to the Off mode.

Pressing the Off mode button resets all active faults.

Manual Run Mode

When in Manual Run mode, the generator set starts and continues to run until the control is put into the Off mode. Pressing the **Off** button initiates a normal shutdown sequence that does not include a time delay stop. While in the Manual Run mode, any remote start signal is ignored.

Auto Mode

When in Auto mode, the control allows the generator set to be started at any time with a remote signal only. When a remote start signal is received, the generator set starts after a time delay start is completed (default delay is zero seconds).

When all remote start signals are removed, the control performs a normal shutdown sequence which includes a time delay stop (default delay is five minutes).

If the generator set is running in Auto mode and the Off button is pressed, the control immediately stops the generator set and the control transitions to the Off mode.

Sleep Mode

The PowerCommand® control enters a low power (Sleep) mode of operation where the current draw is less than 60 milliamps (DC) at normal battery voltage levels. Sleep mode is automatically disabled. If enabled, the operator panel turns itself off after five minutes of keypad inactivity in the Off or Auto mode. It awakes from the Sleep mode if any button is pressed.

| |
|---|
| NOTICE |
| Sleep mode can be enabled; contact your authorized dealer. |

4 Operation - PowerCommand 1.1

4.1 Safety

WARNING

Toxic Gases

Inhalation of exhaust gases can cause asphyxiation and death.

Use extreme care during installation to provide a tight exhaust system.

Terminate exhaust pipes away from enclosed or sheltered areas, windows, doors, and vents. Do not use exhaust heat to warm a room, compartment, or storage area.

WARNING

Hazardous Voltage

Contact with high voltages can cause severe electrical shock, burns, or death.

Do not open the generator set output box while the generator set is running. Read and observe all warnings and cautions in the generator set manuals.

CAUTION

Hazardous Voltage

Contact with high voltages can cause severe electrical shock, burns, or death.

Make sure that only suitably trained and experienced service personnel perform electrical and/or mechanical service. Even with the power removed, improper handling of components can cause electrostatic discharge.

Only trained and experienced personnel should carry out generator set operations. Before operating the system, the operator should become familiar with all health and safety procedures, warnings, cautions, precautions, and the other documentation supplied with the generator set. (See [Chapter 1 on page 1](#)). Observe all of the warnings and cautions at all times.

NOTICE

Before operating the generator set become familiar with the equipment and how it is operated (including all controls, manually operated valves, and alarm devices). Safe and efficient operation can only be achieved if the generator set is operated correctly.

4.2 Introduction

This section describes the operation of the generator set. The text should be read in conjunction with the Control System section of this manual.

All indicators, control switches/buttons, and graphical display are located on the face of the Operator Panel.

4.3 Operating Recommendations

Running-In

Refer to the Maintenance section of this manual. Special "running-in" oils are not recommended for new or rebuilt Cummins engines. Use the same type of oil during "running-in" as is used in normal operation.

The engine should be run at varying loads during the first few hours of operation to allow the components to "bed in." Avoid long periods of light load or full load running particularly during the early life of the engine.

No Load Operation

Periods of no load operation should be held to no longer than 15 minutes. Long periods of no load operation can result in engine and (if fitted) diesel particulate filter damage.

If it is necessary to keep the engine running for long periods of time when no electric output is required, best engine performance will be obtained by connecting a load of at least 30% rated load, but not to exceed rated load. Such a load could consist of a heater element or load bank.

Exercise Period

Generator sets on continuous standby must be able to go from a cold start to being fully operational in a matter of seconds. This can impose a severe burden on engine parts.

Regular exercising keeps engine parts lubricated, prevents oxidation of electrical contacts, and in general helps provide reliable engine starting.

Exercise the set for a minimum of ten minutes off-load at least once a week and for a minimum of 30 minutes with load at least once each month so that the engine reaches normal operating temperatures.

Low Operating Temperatures

NOTICE

Operating engines at idle (650 to 1000 rpm) in cold ambient temperatures wastes fuel, accelerates wear, and can result in serious engine damage. Under low temperature conditions, incomplete combustion will occur, allowing deposits of unburned tars and carbon to buildup on the valve guide and valves, and eventually cause valve sticking.

In cold climates it is critical that the following items be appropriately maintained and selected based on ambient operating temperatures. Check to be sure:

- The battery is properly sized.
- An appropriate mixture of antifreeze is used in the cooling system.
- The proper grade of fuel is being used.
- The correct weight of engine oil is being used.

Use a coolant heater if a separate source of power is available. The optional heater available from Cummins will help provide reliable starting under adverse weather conditions. Make sure the voltage of the separate power source is correct for the heater element rating.

High Operating Temperatures

In high ambient temperatures, when operating at full load, it is normal for the high temperature warning to be given. This indicates that the engine is operating near to its maximum capacity and is normal. If operation in high temperature environments is anticipated, increase the frequency of checks for coolant level, obstructions of cooling air inlets and outlets, and debris at the radiator.

Refer to the generator set nameplate for the maximum operating temperature, if applicable.

Operating Conditions

NOTICE

All generator sets supplied by Cummins must be run under the following operating conditions, and in accordance with the operating information contained within the literature package supplied with each generator set.

Prime Power Rating (PRP) for Variable Load Applications

The Prime Power Rating (PRP) is the maximum power available during a variable load sequence which may be run for an unlimited number of hours per year, between the stated maintenance intervals and under the stated ambient conditions. All maintenance must be carried out as prescribed in Cummins manuals. Prime power applications fall into one of the following two categories:

- Unlimited time prime power (for variable load applications)

Prime power is available for an unlimited number of annual operating hours in variable load applications. The permissible average power output under variable load shall not exceed a 70% average of the prime power rating during any operation of 250 hours. The total operating time at 100% prime power shall not exceed 500 hours per year. A 10% overload capability is available for a period of 1 hour within a 12-hour period of operation, in accordance with ISO 8528-1 2005. Total operating time at the 10% overload power shall not exceed 25 hours per year.

- Limited running time prime power (for constant load applications) (LTP)

Prime power is available for a limited number of hours in a non-variable load application. It is intended for use in situations where power outages are contracted, such as utility power curtailment. Generator sets may be operated in parallel with the public utility up to 750 hours per year at power levels never to exceed the prime power rating. No sustained overload capability is available at this rating. The customer should be aware, however, that the life of any generator set will be reduced by constant high load operation. Any operation exceeding 750 hours per year at the prime power rating should use the Continuous Power Rating.

Emergency Standby Power Rating (ESP) for Variable Load Applications

The Emergency Standby Power Rating (ESP) is applicable for supplying emergency power for the duration of a utility power interruption, between the stated maintenance intervals and under the stated ambient conditions. All maintenance must be carried out as prescribed in Cummins manuals. No overload capability is available for this rating and utility parallel operation is not permitted at the standby power rating. For applications requiring sustained utility parallel operation, the limited time prime power rating or continuous power rating must be utilized as applicable.

This rating is applicable to installations served by a reliable normal utility source. Generator sets should be sized for a maximum average load factor of 80% of the standby power rating with a maximum of 200 hours of operation per year, which includes less than 25 hours per year at the standby power rating. In installations served by unreliable utility sources (where outages last longer or occur more frequently), where operation is likely to exceed 200 hours per year, the prime power rating should be applied. The standby rating is only applicable for emergency and standby applications where the generator set serves as the back up to the normal utility source. Negotiated power outages are not considered as emergencies.

4.4 Generator Set Operation

WARNING

Combustible Vapors

Do not operate an engine where there are or can be combustible vapors. These vapors can be sucked through the air intake system and cause engine acceleration and overspeeding, which can result in a fire, an explosion, personal injury and extensive property damage.

Correct care of your engine will result in longer life, better performance, and more economical operation.

Cummins Inc. does not know how you will use your generator set. The equipment owner and operator, therefore, is responsible for safe operation in the installation site environment. Consult your authorized Cummins dealer for further information.

NOTICE

Diesel engines only: Cummins Inc. recommends the installation of an air intake shutoff device or a similar safety device to minimize the risk of overspeeding where an engine will be operated in a combustible environment.

NOTICE

Long periods of idling (more than ten minutes) can damage an engine. Do not idle the engine for excessively long periods.

Sequence of Operation

NOTICE

The following sequences are based on an approximate time duration. Your generator set may vary slightly from the timing diagrams in this manual. All referenced times are based on default control settings. The following sequences are applicable to generator sets connected to a single phase RA series transfer switch.

Power Outage Sequence

The sequence of operation after a power outage (when the generator set is in Auto Mode) is as follows:

1. In normal operation, the utility power is running to the transfer switch and then to the building load, and the generator set is off.
2. The utility power turns off (power outage).

3. One second after the power outage, the transfer switch sends the command to the generator set to start.
4. The generator set starts and provides voltage to the transfer switch, but the transfer switch does not switch (allowing the voltage to go to the building) until after a delay.

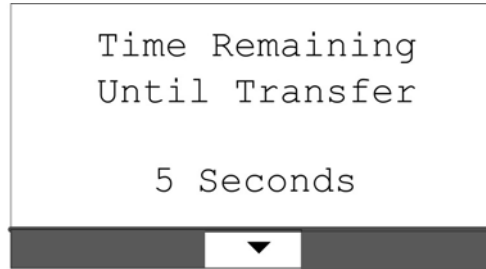

FIGURE 18. TIME REMAINING UNTIL TRANSFER SCREEN

5. Five seconds after starting, the generator set provides a signal to the transfer switch to transfer the building load to the generator set.

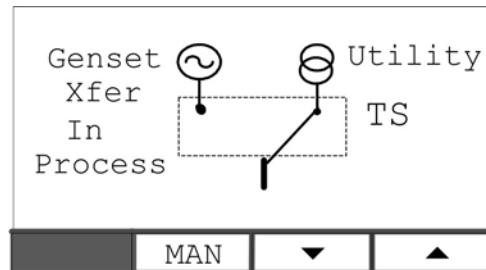

FIGURE 19. BUILDING LOAD TRANSFER IN PROCESS

6. The transfer switch switches the generator set power to the building load. The building is now running on generator power.

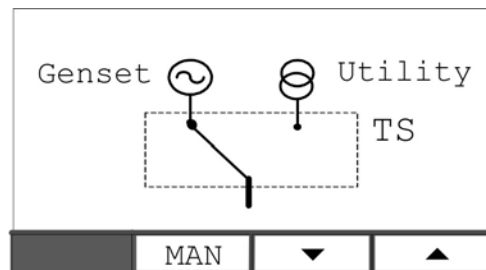

FIGURE 20. GENERATOR SET POWERING BUILDING LOAD

7. When the utility power is back and providing voltage to the transfer switch, the transfer switch waits for utility power stability.

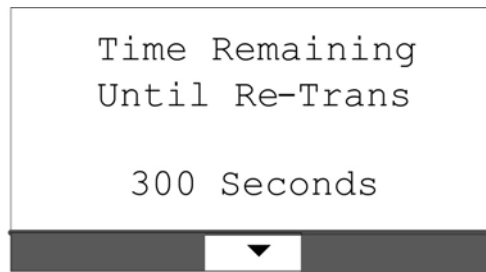

FIGURE 21. TIME REMAINING UNTIL RE-TRANSFER

8. When the utility power is stable for 5 minutes, the transfer switch switches back to utility power.

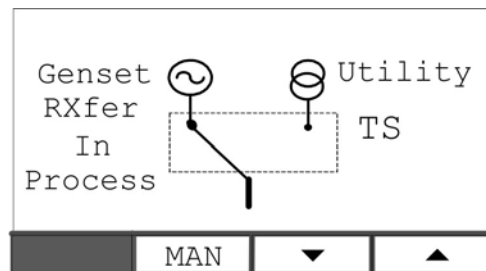

FIGURE 22. BUILDING LOAD TRANSFER IN PROCESS

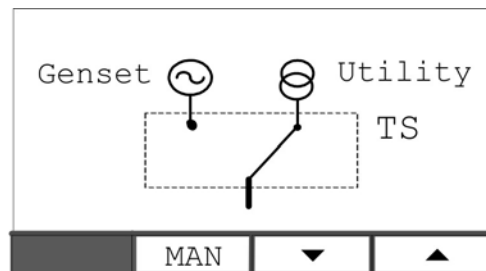

FIGURE 23. UTILITY POWERING BUILDING LOAD

9. The generator set runs for a 5-minute cooldown and shuts off.

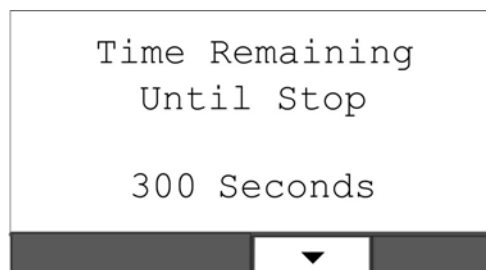

FIGURE 24. TIME REMAINING UNTIL STOP

10. Normal operation resumes.

Exercise Sequence

The exercise sequence when the programmed exercise time is realized (the generator set is in Auto Mode) is as follows:

1. The generator set starts and runs.

- The Exerciser Scheduler On screen displays every 3 seconds and toggles between the existing Information screen that is displayed for 1 second.

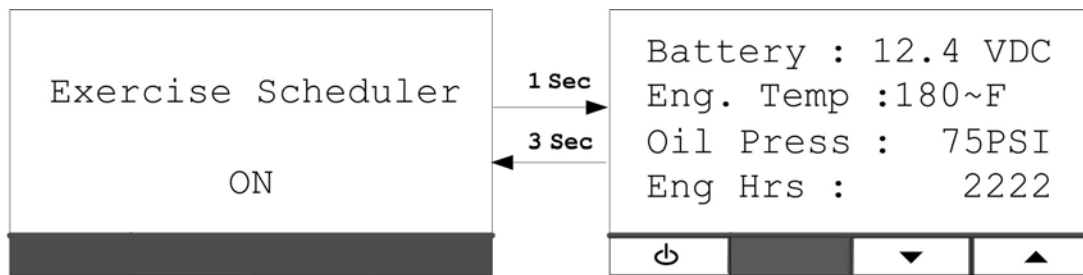

FIGURE 25. EXERCISER SCHEDULER SCREEN AND INFORMATION SCREEN TOGGLE - EXAMPLE

- The transfer switch is not commanded to switch the building load to the generator set.

NOTICE

The user may navigate to other screens from the Information screens during this duration. No functional keys are active on the Exerciser Scheduler On screen.

- The generator set stops after programmed exercise run time.

Manually Starting the Generator Set Sequence

If the generator set is manually started with the standard operator panel, HMI211 (the generator set is in Man Mode), the sequence is as follows:

NOTICE

Open the generator set main line circuit breaker to prevent the transfer switch from transferring building load to the generator set.

- In normal operation, the utility power is running to the transfer switch and then to the building load, and the generator set is off.
- Manually start the generator set via the standard control (HMI211) mounted on the generator set.

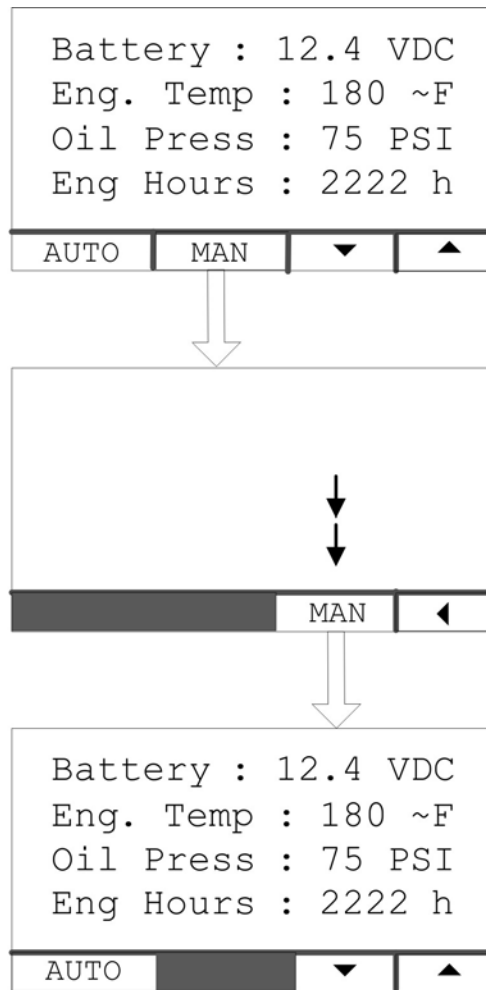

FIGURE 26. MANUAL START SCREEN, STANDARD OPERATOR PANEL

- 3. The generator set starts and provides voltage to the transfer switch.
- 4. The generator set provides a signal to the transfer switch to transfer the building load to the generator set.

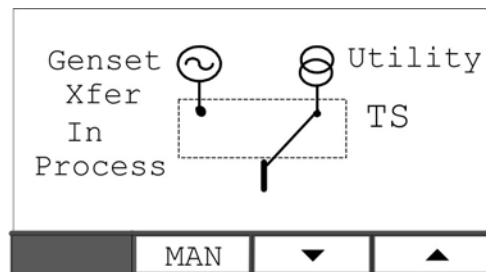

FIGURE 27. BUILDING LOAD TRANSFER IN PROCESS

- 5. The transfer switch switches the generator set power to the building load. The building is now running on generator power.

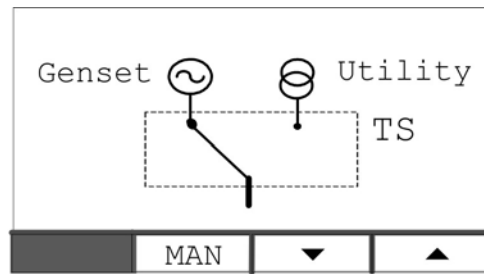

FIGURE 28. GENERATOR SET POWERING BUILDING LOAD

6. Press the Off button to switch the load back to the utility power.

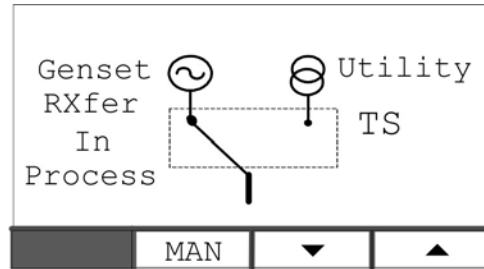

FIGURE 29. BUILDING LOAD TRANSFER IN PROCESS

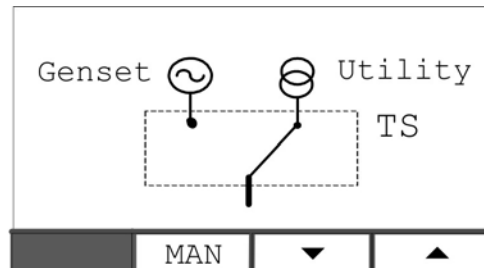

FIGURE 30. UTILITY POWERING BUILDING LOAD

7. Normal operation resumes.

Remote Starting the Generator Set Sequence

If the generator set is remote started with the in-home operator panel accessory, if equipped (the generator set is in Auto Mode), the sequence is as follows:

1. In a normal operation, the utility power is running to the transfer switch and then to the building load, and the generator set is off.
2. The generator set-mounted control (HMI211) is set in Auto Mode.

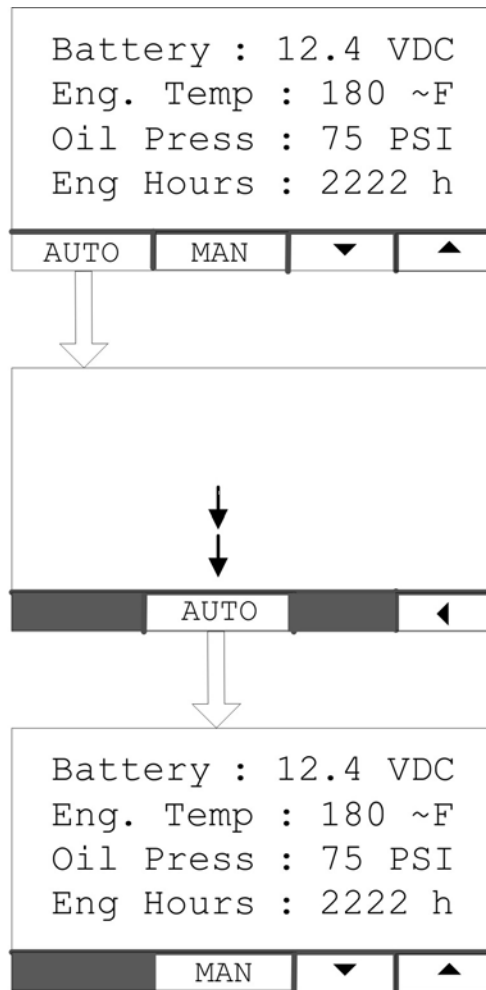

FIGURE 31. HMI211 SET IN AUTO MODE

3. Manually start the generator set via the in-home operator panel.

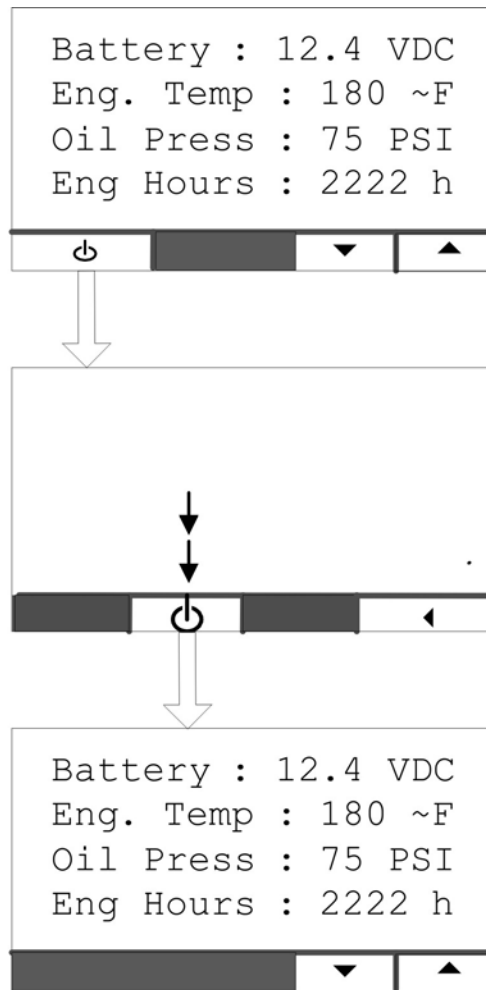

FIGURE 32. MANUAL START SCREEN, IN-HOME OPERATOR PANEL

- 4. The generator set starts and provides voltage to the transfer switch, but the transfer switch does not switch (allowing the voltage to go to the building) until after a delay.

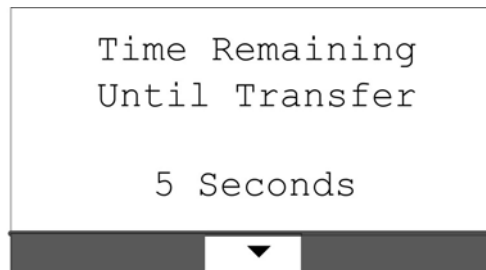

FIGURE 33. TIME REMAINING UNTIL TRANSFER SCREEN

- 5. Five seconds after starting, the generator set provides a signal to the transfer switch to transfer the building load to the generator set.

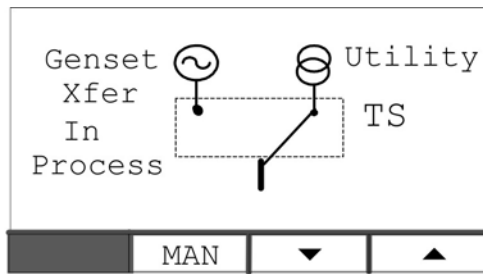

FIGURE 34. BUILDING LOAD TRANSFER IN PROCESS

6. The transfer switch switches the generator set power to the building load. The building is now running on generator power.

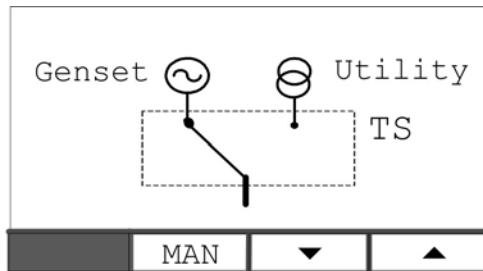

FIGURE 35. GENERATOR SET POWERING BUILDING LOAD

7. When the remote display Stop button is pressed, the transfer switch switches back to utility power after a 5 minute retransfer delay.

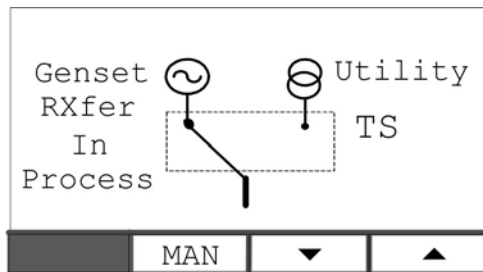

FIGURE 36. BUILDING LOAD TRANSFER IN PROCESS

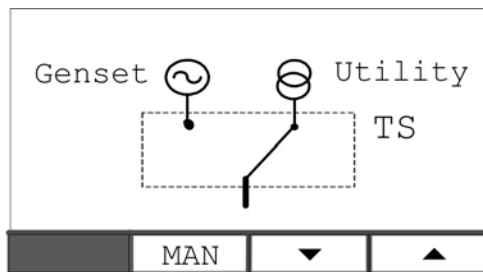

FIGURE 37. UTILITY POWERING BUILDING LOAD

8. The generator set runs for a 5-minute cooldown and shuts off.

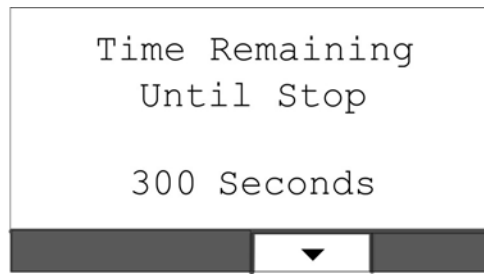

FIGURE 38. TIME REMAINING UNTIL STOP

9. Normal operation resumes.

4.5 Before Starting

NOTICE

One operator should be in complete charge, or working under the direction of someone who is in charge. Remember that, upon starting the engine, cables and switchgear will become energized, possibly for the first time. Furthermore, equipment that does not form part of the generator set installation may become electrically charged. Only authorized and competent personnel should carry out this work.

NOTICE

Make sure that all pre-start checks are carried out before starting the generator set. Do not attempt to start the generator until it is safe to do so. Warn all others in the vicinity of both the generator and the connected load equipment that the generator set is about to start.

NOTICE

Do not use the Emergency Stop switch to shut down an engine unless a serious fault develops. The Emergency Stop push-switch must not be used for a normal shutdown as this prevents a cooling down run in which the lubricating oil and engine coolant carry the heat away from the engine combustion chamber and bearings in a safe manner.

NOTICE

Diesel engines only: Avoid no load running for other than short periods. A minimum loading of 30% is recommended. This loading will help to prevent the build up of carbon deposits in the injectors, due to unburned fuel, and reduce the risk of fuel dilution of the engine lubricating oil.

Before attempting to start the generator set, the operator should read through this entire manual and the specific engine manual provided as part of the documentation pack supplied with the generator set. It is essential that the operator be completely familiar with the generator set and the PowerCommand® control.

The subsections below cover the systems used to start and stop the generator set.

Before starting the generator set, make sure that exhaust and fuel fittings are tight and properly positioned, and that proper maintenance and pre-start checks have been performed.

During starting automatic checks are carried out for the integrity of various protection systems. The PowerCommand® control will not allow the generator set to continue the starting sequence if the integrity of a sensor is considered to be in doubt.

The generator set can be configured for a number of starting cycles (one to seven) with set times for crank and rest periods for all starting modes (manual/remote). The default setting is for three start cycles, composed of fifteen seconds of cranking and 30 seconds of rest.

| NOTICE |
|--|
| The number of starting cycles, and the crank and rest times are set from within the Setup menu. Trained and experienced service personnel are required to change the default setting. Contact your authorized dealer. |

Preheat Delayed Starting

Engine start-up may be delayed for up to 15 seconds due to engine starting aid activation.

Coolant temperature is used by the control to determine the pre-start time duration of the starting aid.

Operator's Pre-Start Checks

| ⚠ WARNING |
|---|
| <p><i>Electrical Short Circuit</i> <i>An electrical short circuit may result in catastrophic failure, severe personal injury or death.</i> <i>Generators must be dry before the generator set is operated.</i></p> |

| ⚠ WARNING |
|--|
| <p><i>Coolant under Pressure</i> <i>Hot coolant is under pressure in the radiator system and can cause severe scalding.</i> <i>Do not attempt to remove a radiator pressure cap while the generator set is running, or is off but still hot. Always allow the coolant to cool before releasing the pressure and removing the cap.</i></p> |

TABLE 18. OPERATOR'S PRE-START CHECKS

| Check | Description |
|-------|-------------|
|-------|-------------|

| | |
|--------------------------------|---|
| Fuel Supply | Make sure the fuel tank is filled to the normal level with clean water-free fuel and that the fuel system is primed and all the valves required for operation are open. Make sure there are no leaks and that all fittings are tight. |
| Lubrication | With the engine not running, check the engine lubrication oil level and ensure that the correct level is always maintained. |
| Coolant | Check the engine coolant level and make sure that the level is always maintained at the coolant expansion tank. Fill the cooling system to the bottom of the fill neck in the radiator fill or expansion tank. Do not check while the engine is hot. The coolant in the recovery bottle should be between the Add and Full marks. |
| Cooling Air Inlet/Outlet | Make sure that the cooling air inlets/outlets are unobstructed (if applicable). |
| Exhaust Outlet | Make sure that exhaust components are secured and not warped; that the exhaust outlet is unobstructed; that no combustible materials are near the system, and gases are discharged away from building openings. Make sure that there are no leaks and that all fittings are tight. |
| Batteries | Make sure that the batteries are charged and that all connections are correct and tight. |
| AC Powered Auxiliary Equipment | Make sure that all auxiliary equipment is receiving power from the customer's supply (if applicable). |
| Emergency Stop | Make sure that the emergency stop button is fully operational (if applicable). |

Starting at the Operator Panel (Manual Run Mode)

To start the generator set in the Manual Run mode, select the  symbol from the menu bar of the operator panel.

NOTICE

Any Remote Start/Stop signal is ignored while in Manual Run mode.

The PowerCommand® 1.1 control initiates a starter cranking signal and performs an automatically sequenced manual start. This activates the engine control system and the starting procedure. The starter begins cranking, and after a few seconds the engine starts and the starter disconnects.

In the Manual Run mode, the control will not complete the Time Delay to Start or Time Delay to Stop.

The Not in Auto red LED, and the Manual Run green LED, are lit.

If the engine does not start, the starter disengages after a specified period of time and the control indicates a Fail to Start Shutdown.

Wait a minimum of two minutes for the starter motor to cool and then repeat the starting procedure. If the engine does not run after a second attempt, refer to the Troubleshooting section..

Cold Starting with Loads

Use a coolant heater if a separate source of power is available. The optional heater available from Cummins will help provide reliable starting under adverse weather conditions. Be sure the voltage of the separate power source is correct for the heater.

Cummins recommends equipping standby generator sets (life safety systems) with engine water jacket coolant heaters to maintain the coolant at a minimum of 32 °C (90 °F) and, for most applications, accept the emergency load in ten seconds or less. Although most Cummins generator sets will start in temperatures down to -32 °C (-25 °F) when equipped with engine water jacket coolant heaters, it might take more than ten seconds to warm the engine up before a load can be applied when ambient temperatures are below 4 °C (40 °F).

To advise the operator of a possible delay in accepting the load, the Low Coolant Temp (code 1435) message, in conjunction with illumination of the Warning LED, is provided. The engine cold sensing logic initiates a warning when the engine water jacket coolant temperature falls below 21 °C (70 °F). In applications where the ambient temperature falls below 4 °C (40 °F), a cold engine may be indicated even though the coolant heaters are connected and functioning correctly. Under these conditions, although the generator set may start, it may not be able to accept load within ten seconds. When this condition occurs, check the coolant heaters for correct operation.

Checking Coolant Heater Operation

CAUTION

Hot surfaces.

Contact with the cooling system or engine can cause serious burns.

Do not touch the cooling system or engine until they are cool.

The coolant heater is thermostatically controlled and does not operate until a minimum temperature is sensed.

Do not touch the cooling system outlet hose. The coolant heater is operating if radiant heat can be felt with your hand held close to the outlet hose and the engine is not running.

4.6 Stopping

NOTICE

Run the generator set at no load for three to five minutes before stopping. This allows the lubricating oil and engine coolant to carry heat away from the combustion chamber and bearings.

Stopping at Operator Panel (Manual Mode)

The control will not respond to any remote stop signal when in **Manual Run** mode. When in **Manual Run** mode, pressing the **Off** button will initiate a normal (Manual) shutdown sequence.

In the **Manual Run** mode the control will not complete the time delay stop.

Reduce engine heat before pressing the **Off** button.

1. Remove the load.
2. Run the set for five minutes.
3. Press the **Off** button.

Stopping from Remote Location (Auto Mode)

In Auto mode, the generator set control allows the generator set to be started with a remote start signal only.

If the control receives a remote stop signal, the generator set will complete its normal shutdown sequence which includes a time delay stop.

If the generator set is running in Auto mode and the local display Off button is pressed, the control immediately stops the generator set.

Code 1433 or 1434 - Emergency Stop

The optional Local Emergency Stop button (or Remote Emergency Stop button) is located on the front of the operator panel. This is a mechanically latched switch that will unconditionally stop the engine when pressed, bypassing any time delay to stop. Push this button in for Emergency Shutdown of the engine.

NOTICE

If the generator set is not running, pushing the Emergency Stop button in prevents the starting of the engine, regardless of the start signal source (Manual or Auto - remote).

When the Emergency Stop Button is pressed, the display panel indicates the Shutdown condition by illuminating the red Shutdown status LED (shown below):



One of the following messages will appear on the graphical LCD display, depending on the button pushed:

- Fault Number: 1433 LOCAL EMERGENCY STOP
- Fault Number: 1434 REMOTE EMERGENCY STOP

To reset:

1. Pull (or twist and pull) the button out.
2. Press the Off button on the Operator Panel to acknowledge this action.
3. Press the Auto or Manual Run button, as previously determined.

NOTICE

Do not use an Emergency Stop button to shut down an engine unless a serious fault develops. The Emergency Stop button must not be used for a normal shut-down because this will prevent a cooling down run in which the lubricating oil and engine coolant carry away heat from the engine combustion chamber and bearings in a safe manner.

NOTICE

Make sure the remote start control is not active; otherwise, when the Emergency Stop is reset, the generator set could start running.

NOTICE

Make sure that the cause of the emergency stop is fully investigated and remedied before a fault Reset and generator Start are attempted.

This page is intentionally blank.

5 Maintenance

5.1 Maintenance Safety

 **WARNING**

Automated Machinery

Accidental or remote starting of the generator set can cause severe personal injury or death.

Isolate all auxiliary supplies and use an insulated wrench to disconnect the starting battery cables (negative [-] first).

 **WARNING**

Hydrogen Gas

Arcing can ignite explosive hydrogen gas given off by batteries, causing severe personal injury or death. Arcing can occur when cables are removed or replaced, or when the negative (-) battery cable is connected and a tool used to connect or disconnect the positive (+) battery cable touches the frame or other grounded metal part of the generator set.

Insulated tools must be used when working in the vicinity of the batteries. Always remove the negative (-) cable first and reconnect last.

 **WARNING**

Explosive Fumes

Arcing can ignite explosive fumes causing severe personal injury or death.

Make sure hydrogen from the battery, engine fuel and other explosive fumes are fully dissipated before working on the generator set.

 **WARNING**

Working at Heights

Using the incorrect equipment when working at heights can result in severe personal injury or death.

Suitable equipment for performing these tasks must be used in accordance with the local guidelines and legislation. Failure to follow these instructions can result in severe personal injury or death.

⚠ WARNING**Access**

Using the generator set or part of as a means of access when attaching lifting shackles, chains, or other lifting aids, may damage the generator set, causing severe personal injury or death.

Do not use the generator set as a means of access. Failure to follow these instructions can result in severe personal injury or death.

⚠ WARNING**Exposed Terminations**

Some panel internal components may have live exposed terminations even if the generator set is not running. Voltages are present which can cause electrical shock, resulting in personal injury or damage to equipment.

Isolate all external electrical supplies prior to access of the control panel

NOTICE

Only authorized and qualified maintenance technicians who are familiar with the equipment and its operation should carry out maintenance.

NOTICE

Dependent upon the control system fitted, this unit may operate automatically and could start without warning.

NOTICE

Always disconnect a battery charger from its AC source before disconnecting the battery cables. Failure to do so can result in voltage spikes high enough to damage the DC control circuits of the generator set.

All maintenance tasks must be performed, but be sure to assess them for health and safety risks before starting. For example, perform a task with someone present if doing so will add significantly to the safety of the task.

Read, understand, and comply with all Caution, Warning, and Danger notes in this section, the Important Safety Instructions section, and the documentation supplied with the generator set.

Make sure that adequate lighting is available.

Locking the Generator Set Out of Service

NOTICE

Automated Machinery

Accidental or remote starting of the generator set can cause severe personal injury or death.

Isolate all auxiliary supplies and use an insulated wrench to disconnect the starting battery cables, negative (–) cable first.

Before any work is carried out for maintenance, etc., the generator set must be immobilized. Even if the generator set is put out of service by pressing the Off switch on the Operator Panel (or the STOP button if applicable), the generator set cannot be considered safe to work on until the engine is properly immobilized, as detailed in the following procedure.

NOTICE

Refer also to the engine-specific Operator Manual, if applicable. This manual contains specific equipment instructions that may differ from the standard generator set.

To immobilize the generator set:

1. Press the Off switch from the display and then press the E-Stop button to shut down the engine. This will prevent the starting of the generator set regardless of the Start signal source and will therefore provide an additional safety step for immobilizing the generator set. Alternatively, make sure the generator set is in manual mode (which allows it to be started by manually pushing the buttons).

NOTICE

When the E-Stop button is pressed, the Operator Panel indicates the Shutdown condition by illuminating the red Shutdown status LED  and displaying a message on the graphical LCD display.

2. Thoroughly ventilate the generator set before disconnecting any leads.
3. Turn off and disconnect the heater (where fitted) from the AC source before disconnecting the battery cables.
4. Turn off and disconnect the battery charger (where fitted) from the AC source before disconnecting the battery cables.
5. Turn off the fuel supply to the engine.
6. Disconnect the battery. Disconnect the negative (–) cable first, using an insulated wrench.
7. Place warning notices at each of the above locations that state, "Maintenance in Progress – Immobilized for Safe Working."

5.2 Periodic Maintenance

 **WARNING**

Electrical Generating Equipment

Accidental or remote starting of the generator set can cause severe personal injury or death.

Before working on the generator set, make sure that the generator set is in Off mode, disable the battery charger, and remove the negative (-) battery cable from the battery to prevent starting.

The table(s) that follow show the recommended service intervals for a generator set on standby service. If the generator set will be subjected to extreme operating conditions, the service intervals should be reduced accordingly.

At each scheduled maintenance interval, perform all previous maintenance checks that are due for scheduled maintenance.

Some of the factors that can affect the maintenance schedule are:

- Extremes in ambient temperature
- Exposure to elements
- Exposure to salt water
- Exposure to windblown dust or sand

Consult with your authorized Cummins Inc. service provider if the generator set will be subjected to any extreme operating conditions, and determine if extra protection or a reduction in service intervals is needed. Use the engine hours shown on the system status screen to keep an accurate log of all service performed for warranty support. Perform all service at the time period indicated, or after the number of operating hours indicated, whichever comes first.

Repair or replace worn, damaged, or improperly functioning components identified during periodic maintenance procedures.

Periodic Maintenance Guidelines

Regularly performing the following periodic maintenance tasks greatly reduces the chances of a generator set shutdown:

- Maintain an appropriate oil level.
- Keep battery connections clean and tight.
- Do not overload the generator set.
- Keep the air inlet and outlet openings clear.

Periodic Maintenance Schedule

NOTICE

Perform maintenance tasks as specified using daily or hourly periods, whichever is sooner.

TABLE 19. PERIODIC MAINTENANCE SCHEDULE

| Maintenance Type | Action | Daily | 250 Hrs. or 3 Mos. | 500 Hrs. or 6 Mos. | 1000 Hrs. or 1 Yr. | 2000 Hrs. or 2 Yrs. | 5000 Hrs. or 4 Yrs. |
|----------------------------------|------------------------|-------|--------------------|----------------------|--------------------|---------------------|---------------------|
| Air Intake Piping | Check | ■ | | | | | |
| Air Intake Piping | Inspect | | ■ ³ | | | | |
| Engine Lubricating Oil Level | Check | ■ | | | | | |
| Crankcase Breather Tube | Inspect | ■ | | | | | |
| Engine Coolant Level | Check | ■ | | | | | |
| Fuel-Water Separator | Drain | ■ | | | | | |
| Fuel Tanks | Drain water & sediment | | ■ | | | | |
| Air Cleaner Restriction | Check | | ■ | | | | |
| Charge Air Cooler | Check | | ■ ³ | | | | |
| Charge Air Piping | Check | | ■ ³ | | | | |
| Radiator Hoses | Check | | ■ ³ | | | | |
| Fan, Cooling | Check | | ■ ³ | | | | |
| Coolant Level | Check | | ■ ³ | | | | |
| Drive Belts | Check | | ■ ³ | | | | |
| Rupture Basin Leak Detect Switch | Test | | | ■ | | | |
| Engine Coolant - Antifreeze | Check | | | ■ ^{1, 2, 3} | | | |
| Fuel Filter (Spin-On Type) | Change | | | ■ ^{1, 2, 3} | | | |
| Lubricating Oil and Filters | Change | | | ■ ^{1, 2, 3} | | | |

| Maintenance Type | Action | Daily | 250 Hrs. or 3 Mos. | 500 Hrs. or 6 Mos. | 1000 Hrs. or 1 Yr. | 2000 Hrs. or 2 Yrs. | 5000 Hrs. or 4 Yrs. |
|---|----------------------|-------|--------------------|----------------------|--------------------|---------------------|---------------------|
| Radiator Pressure Cap | Check | | | ■ ^{1, 2, 3} | | | |
| Cooling Fan Belt Tensioner | Check | | | | ■ ³ | | |
| Fan Hub, Belt-Driven | Check | | | | ■ ³ | | |
| Cooling System | Drain, flush, & fill | | | | | ■ ^{2, 3} | |
| Vibration Damper, Rubber | Check | | | | | ■ ^{2, 3} | |
| Vibration Damper, Viscous | Check | | | | | ■ ^{2, 3} | |
| Overhead Set | Adjust | | | | | | ■ ³ |
| ¹ The lubricating oil and lubricating oil filter interval is determined by the sulfur content of the fuel used, the lubricating oil type used, and the engine rating. See the Engine Oil section. | | | | | | | |
| ² The antifreeze check interval is every oil change or 500 hours or 6 months, whichever occurs first. The operator must use a heavy-duty year-round antifreeze that meets the chemical composition of ASTM D6210. The antifreeze change interval is 2 years or 2000 hours, whichever occurs first. Antifreeze is essential for freeze, overheat, and corrosion protection. | | | | | | | |
| ³ Follow the manufacturer's recommended maintenance procedures for the engine, starter, alternator, generator set, batteries, electrical components, exhaust brake, charge air cooler, radiator, air cleaner, refrigerant compressor, and fan clutch. | | | | | | | |

Maintenance Record

Record all periodic and unscheduled maintenance and service. See the Periodic Maintenance Schedule for a list of scheduled maintenance frequency.

| Date | Engine Hours Meter Reading | Maintenance or Service Performed |
|------|----------------------------|----------------------------------|
| | | |
| | | |
| | | |
| | | |
| | | |
| | | |

| Date | Engine Hours Meter Reading | Maintenance or Service Performed |
|------|----------------------------|----------------------------------|
| | | |
| | | |
| | | |
| | | |
| | | |
| | | |
| | | |
| | | |
| | | |
| | | |
| | | |
| | | |
| | | |
| | | |
| | | |
| | | |
| | | |
| | | |
| | | |
| | | |
| | | |
| | | |
| | | |
| | | |
| | | |
| | | |

Record the name, address, and phone number of your authorized Cummins Inc. service center:

| Name | Address | Phone |
|------|---------|-------|
| | | |

Exercising the Generator Set

| NOTICE |
|---|
| Audible engine RPM variation may be heard when there is no load applied. This is normal and does not affect the generator set performance. |

Exercising the generator set drives off moisture, relubricates the engine, and removes oxides from electrical contacts. The result is better starting, more reliable operation and longer engine life.

The generator set exerciser mode defaults are as follows.

- **Day:** Tuesday
- **Time:** 2:00 pm
- **Period:** Monthly
- **Run Time:** 5 minutes

Refer to the Exercise Settings section of this manual for more information on setting up the exerciser.

Maintenance Procedures - Daily or When Refueling

Monitor fluid levels, oil pressure, and coolant temperature frequently. During operation, be alert for mechanical problems that could create unsafe or hazardous conditions. The following sections cover several areas that should be frequently inspected for continued safe operation.

NOTICE

Components that have guards against inadvertent touching must be visually inspected only. Do not remove the guards to do the inspection.

General Information

Preventive maintenance begins with day-to-day awareness of the condition of the generator set. Before starting the generator set, check and look for:

- Oil and coolant levels
- Leaks
- Loose or damaged parts
- Worn or damaged belts
- Any change in engine noise or performance
- Generator set appearance

Engine Operation Report

The engine must be maintained in good mechanical condition if the operator is to obtain optimum satisfaction from its use. Running reports are necessary to enable programmed or emergency servicing to be carried out.

Comparison and intelligent interpretation of the running report, together with a practical follow-up action will eliminate most failures and emergency repairs.

Most engine problems give an early warning. Look and listen for changes in engine performance, sound, or appearance that can indicate service or repair is needed. Some engine changes to look for and report on are:

- Low lubricating oil pressure
- Low power
- Abnormal water or oil temperature
- Unusual engine noise
- Excessive use of coolant, fuel or lubricating oil
- Any coolant, fuel, or lubricating oil leaks
- Misfire
- Unexplained frequency fluctuation
- Significant vibration

- Excessive white and/or black exhaust smoke.

5.3 Cooling System

NOTICE

Loss of coolant can allow the engine to overheat if it does not have the protection of a shutdown device. This can cause severe damage to the engine. Maintain coolant level for proper operation of high engine temperature shutdown system. If applicable, see the Model Specifications section for more information.

Radiator Check

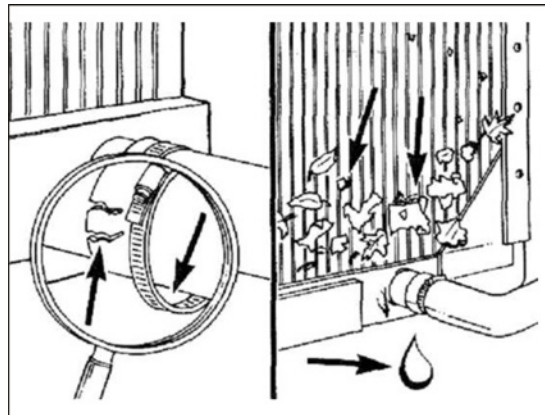

FIGURE 39. RADIATOR CHECK

Check for damaged hoses and loose and damaged hose clamps.

Inspect the exterior of the radiator (through the guarding) for obstructions. During the service life of a radiator a buildup of foreign matter can obstruct the flow of air through the radiator cores, reducing the cooling capability. To continue the efficiency of the radiator, the core will require cleaning.

Cleaning of the radiator core must only be undertaken by suitably trained and experienced service personnel.

Cooling Fan Inspection

⚠ WARNING

Fan Blade Damage

Personal injury can result from a fan blade that has become damaged. Never pull or pry on the fan; this can damage the fan blade(s) and cause fan failure.

A visual inspection of the cooling fan is required daily. Check for loose rivets or retaining bolts (1), for cracks (2), and bent or loose blades (3).

Contact your authorized dealer if the fan is damaged.

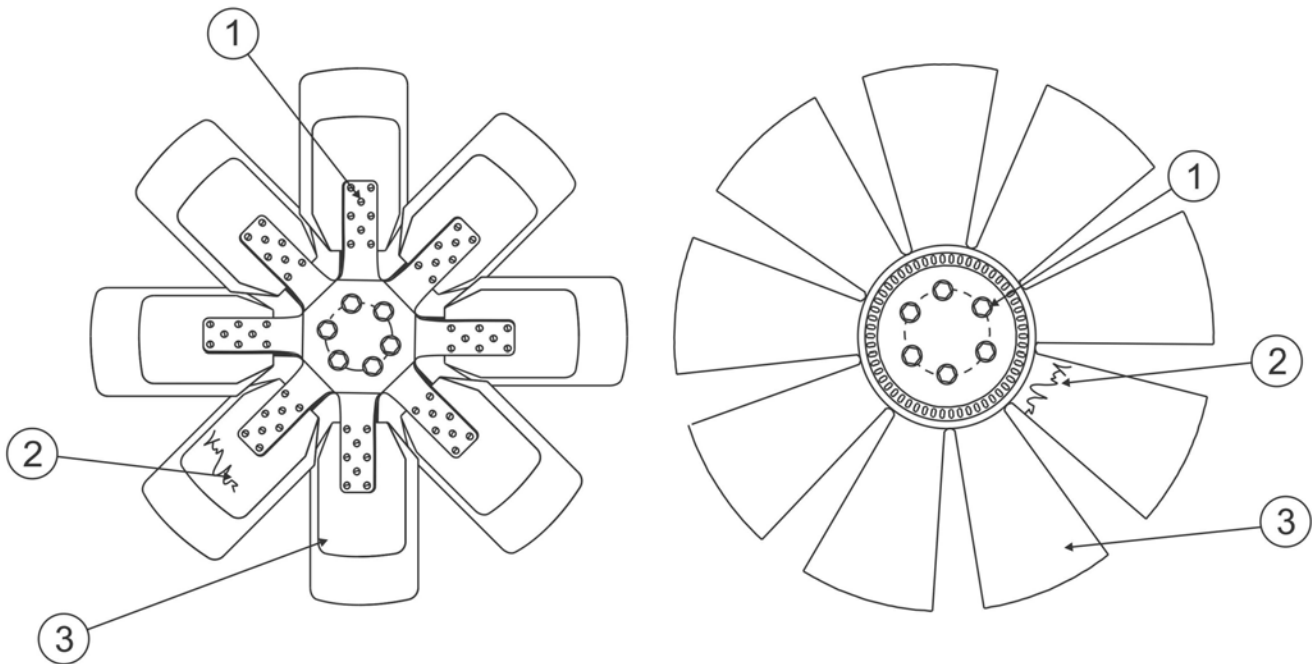

FIGURE 40. COOLING FAN INSPECTION

5.4 Engine Oil

Recommended Engine Oil

Check the oil level prior to starting the generator set to verify that the oil level is between the High and Low marks.

Refer to the engine operator and maintenance manual for the oil specification.

Checking Engine Oil Level

⚠ WARNING

State and federal agencies have determined that contact with used engine oil can cause cancer or reproductive toxicity. Avoid skin contact and breathing of vapors. Use rubber gloves and wash exposed skin. Accidental or remote starting of the generator set can cause severe personal injury or death. Disconnect the negative (-) battery cable and place the control switch in its OFF position before starting work.

⚠ WARNING

Crankcase pressure can blow out hot oil and cause severe burns. Do NOT check oil while the engine is operating.

NOTICE

Check the engine oil level when the engine is not running and is out of Auto mode.

NOTICE

Overfilling can cause foaming or aeration of the oil, and operation below the low mark may cause loss of oil pressure. Do not operate the engine with the oil level below the low mark or above the high mark.

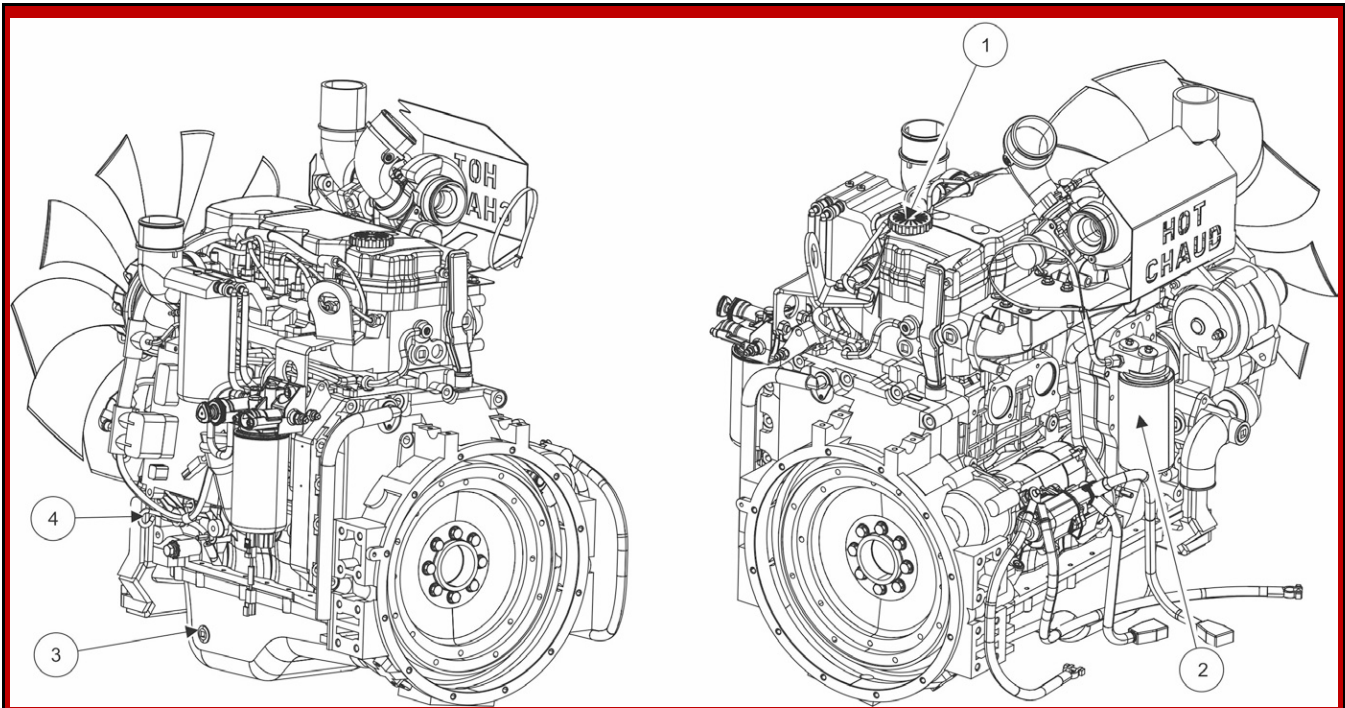

| No. | Description | No. | Description |
|-----|-------------|-----|-------------|
| 1 | Oil Fill | 3 | Oil Drain |
| 2 | Oil Filter | 4 | Dipstick |

FIGURE 41. ENGINE OIL COMPONENTS

To check the engine oil level:

1. Make sure that the engine has not been running for approximately five minutes.
2. Clean off the area surrounding the dipstick port to prevent entry of debris into the oil pan.
3. Pull out the dipstick and wipe it clean.
4. Reinsert and fully seat the dipstick.
5. Remove the dipstick and check the oil level.
6. Reinsert and fully seat the dipstick.

If the engine oil level check shows excessive or insufficient levels of oil (oil level line above the High mark or below the Low mark), oil must be drained or added. Refer to the following sections for instructions and guidelines for draining and adding oil.

Adding or Draining Oil

WARNING

Hot Surfaces

Contact with hot surfaces can cause severe burns. Wear appropriate PPE when working on hot equipment and avoid physical contact with hot surfaces.

WARNING

Hot Engines

Contact with hot engines can cause severe burns. Ensure that the generator set engine has cooled down before adding or draining the oil.

NOTICE

Too much oil can cause high oil consumption. Too little oil can cause severe engine damage. Keep the oil level between the High and Low marks on the dipstick.

Adding Oil

If the oil level is found to be insufficient, oil must be added.

1. Ensure that the oil fill cap area is clean, and prevent debris from entering the engine.
2. Add the appropriate amount of oil, based on the engine oil level check. Refer to the Checking Engine Oil Level section and the Model Specifications section.
3. Recheck the engine oil level. Based on the results, add or drain oil.
4. Clean up and dispose of any oil in accordance with local/state regulations.

Draining Oil

If the oil level is found to be excessive, oil must be drained from the engine.

1. Detach the oil drain hose from the side of the engine.
2. Place the end of the drain hose into an appropriate container.

Refer to local regulations to determine the appropriate container for used oil.

- Open the oil drain valve to release oil from the engine into the appropriate container.
- Recheck the engine oil level. Based on the results, add or drain oil.

- When a sufficient amount of oil has been drained from the system:
 1. Close the oil drain valve.
 2. Wipe the oil drain valve clean.
 3. Re-attach the drain hose to the side of the engine.
 4. Dispose of the used oil in accordance with local/state regulations.

Changing Engine Oil and Oil Filter

WARNING

Automated Machinery

Accidental or remote starting of the generator set can cause severe personal injury or death.

Isolate all auxiliary supplies and use an insulated wrench to disconnect the starting battery cables, negative (-) cable first.

WARNING

Toxic Hazard

State and federal agencies have determined that contact with used engine oil can cause cancer or reproductive toxicity.

Avoid skin contact and breathing of vapors. Use rubber gloves and wash exposed skin.

NOTICE

If the oil and/or oil filter are not reused, dispose of them in accordance with local environmental regulations.

NOTICE

Change the engine oil and filter when the engine is not running and is out of Auto mode.

NOTICE

Change the oil more often in hot and dusty environments.

NOTICE

Cummins highly recommends that any service or maintenance work be performed by qualified technicians.

1. Before changing the oil, the generator set should be operated until the water temperature is approximately 60 °C (140 °F).
2. Make sure the generator set is shut down and disabled:
 - a. Press the generator set's "O" (Off) button to stop the generator set. Allow the generator set to thoroughly cool to the touch.

- b. If applicable, turn off and disconnect the battery charger from the AC source before disconnecting the battery cables.
 - c. Disconnect the negative (–) cable from the battery and secure it from contacting the battery terminals to prevent accidental starting.
3. Drain the oil. Place the end of the drain hose into an appropriate container.

NOTICE

Refer to local regulations to determine the appropriate container for used oil.

4. Remove the oil filter, and clean the filter mounting surface on the engine block. Remove the old gasket if it remains.
5. Make sure the gasket is in place on the new filter and apply a thin film of clean oil to the gasket.
6. Install the new filter until the gasket just touches the block. Turn it an additional 1/2 to 3/4 turn. Do not over-tighten.
7. Remove the container used to collect oil when removing the oil filter.
8. Close the oil drain valve.
9. Add the appropriate amount of oil.

NOTICE

Too much oil can cause high oil consumption. Too little oil can cause severe engine damage. Keep the oil level between the High and Low marks.

10. Operate the engine at idle to inspect for leaks at the lubricating oil filter and the drain plug.
11. Confirm that the correct oil level is in the pan:
 - a. Shut the generator set off and wait 5 minutes.
 - b. Check the engine oil level.
12. Check and repair any leaks identified.
13. Dispose of the used oil and oil filter according to local environmental regulations.

5.5 Diesel Fuel System Safety and Requirements

WARNING

Fuel Ignition

Ignition of fuel can cause serious personal injury or death by fire or explosion.

DO NOT permit any flame, cigarette, or other igniter near the fuel system, or in areas sharing ventilation.

WARNING

Fuel Mixtures

Mixing gasoline or alcohol with diesel fuel, can cause an explosion which may result in severe personal injury or death.

Do not mix gasoline or alcohol with diesel fuels.

NOTICE

Due to the precise tolerances of diesel injection systems, it is extremely important that the fuel be kept clean and free of dirt or water. Dirt or water in the system can cause severe damage to both the injection pump and the injection nozzles.

See the *Model Specifications* section for fuel requirements.

Fuel Level

To avoid condensation problems, keep fuel supply tanks as full as possible by filling them each time the generator set is used. Condensation (water) can cause clogging of the fuel filters, as well as possible freezing problems. In addition, water mixing with the sulfur in the fuel forms acid which can corrode and damage engine parts.

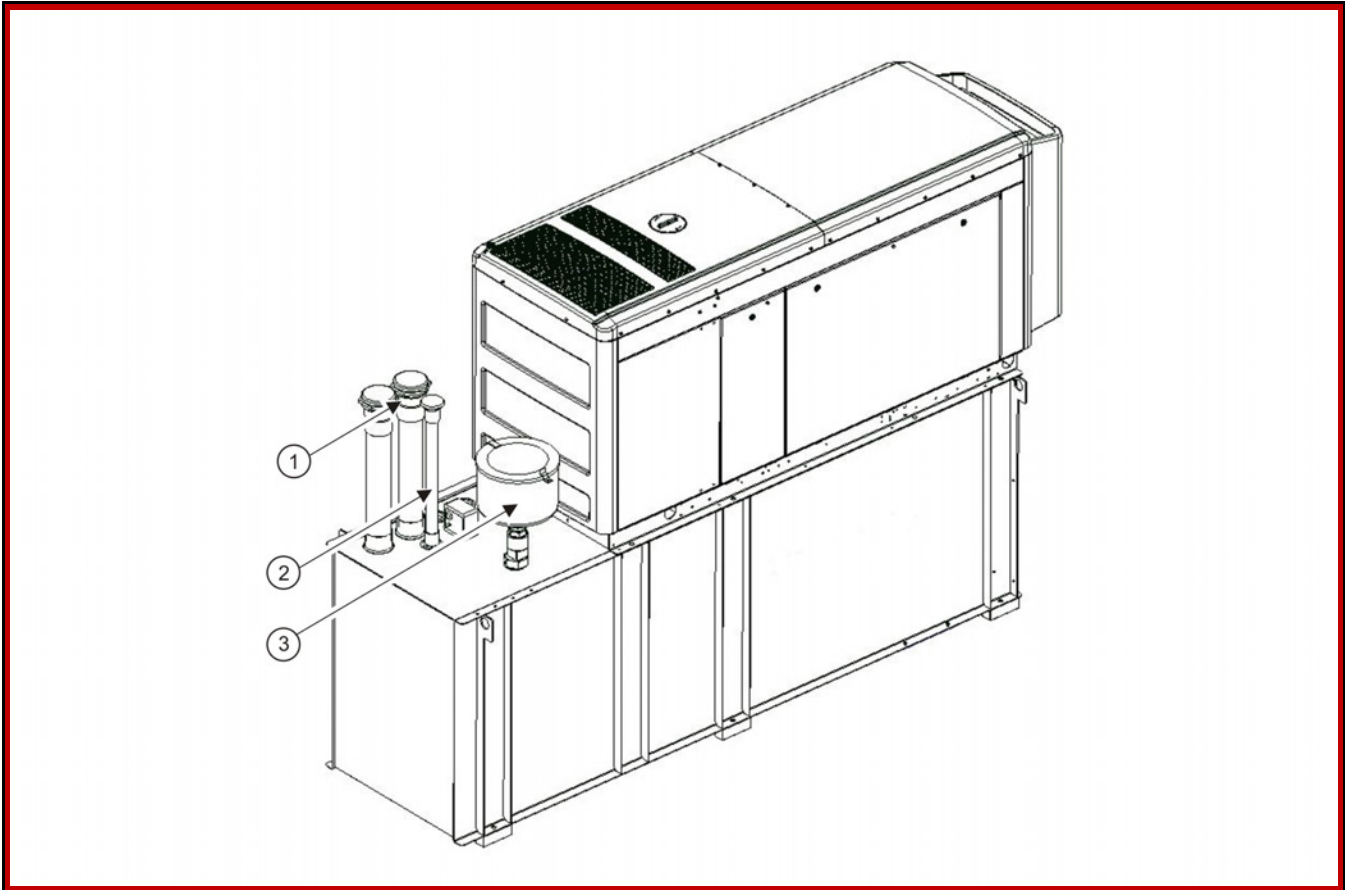

| No. | Description | No. | Description |
|-----|-----------------|-----|----------------------------------|
| 1 | Emergency Vents | 3 | Fuel Fill (shown with spill box) |
| 2 | Normal Vent | | |

FIGURE 42. EXAMPLE OF REGIONAL FUEL TANK OPTION

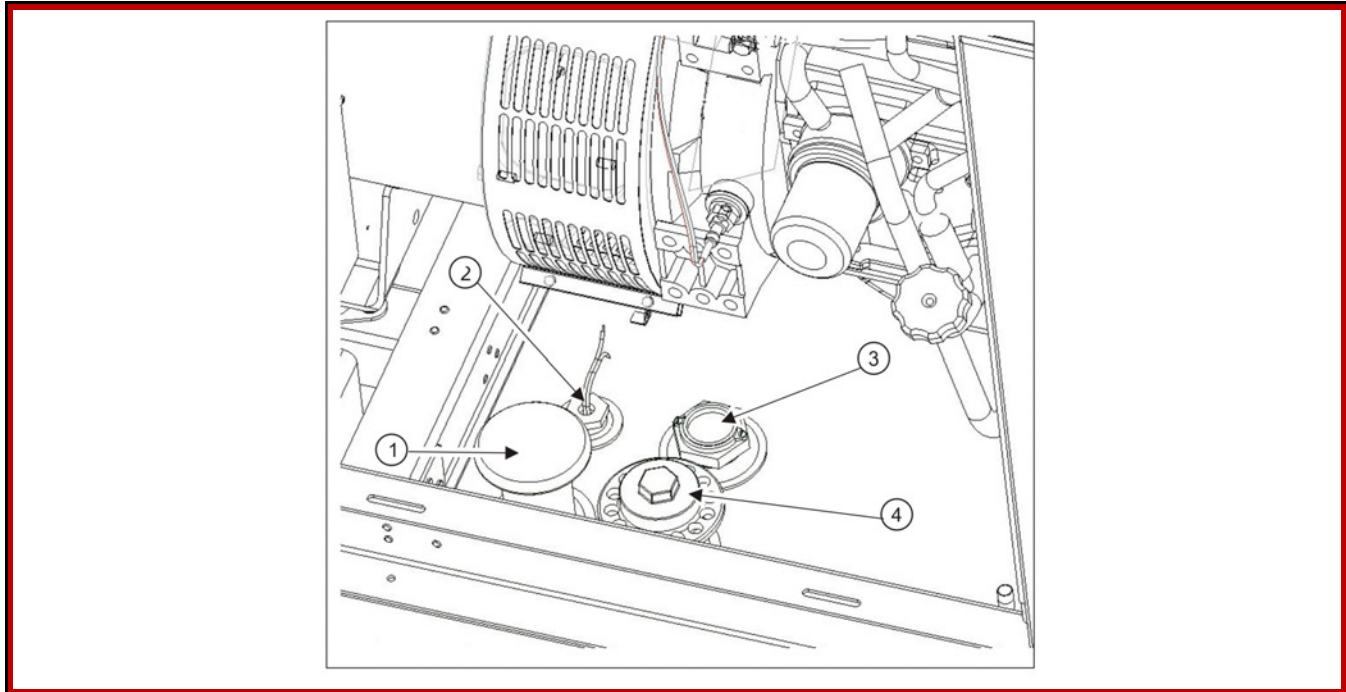

| No. | Description | No. | Description |
|-----|-----------------------|-----|-------------|
| 1 | Normal Vent | 3 | Fuel Gauge |
| 2 | Fuel Low Level Switch | 4 | Fuel Fill |

FIGURE 43. EXAMPLE OF BASIC FUEL TANK OPTION

Fuel/Water Separator (Spin-On Type)

A set-mounted integral fuel/water separator is fitted to provide protection for the engine fuel injection system as water-free fuel supplies cannot be guaranteed.

Drain the water and sediment from the separator daily.

1. Turn off the generator set.
2. Wait 1 minute to remove any pressure in the fuel line.
3. Place a suitable container under the fuel filter.

NOTICE

If more than 60 ml (2 oz) is drained, refilling of the filter is required to prevent hard starting.

4. Turn the valve counterclockwise, four complete turns, until the valve drops down approximately one inch. Drain the filter sump of water until clear fuel is visible.

NOTICE

Do not over tighten the valve. Over tightening can damage the threads.

5. When clear fuel begins to flow out of the drain, push the valve up and turn the valve counterclockwise to close drain valve.
6. Before starting the engine, be sure to remove the container and clean up any fuel spillage.
7. Start the engine and check for any leaks.

NOTICE

The drained liquids must be disposed of in accordance with local environmental regulations.

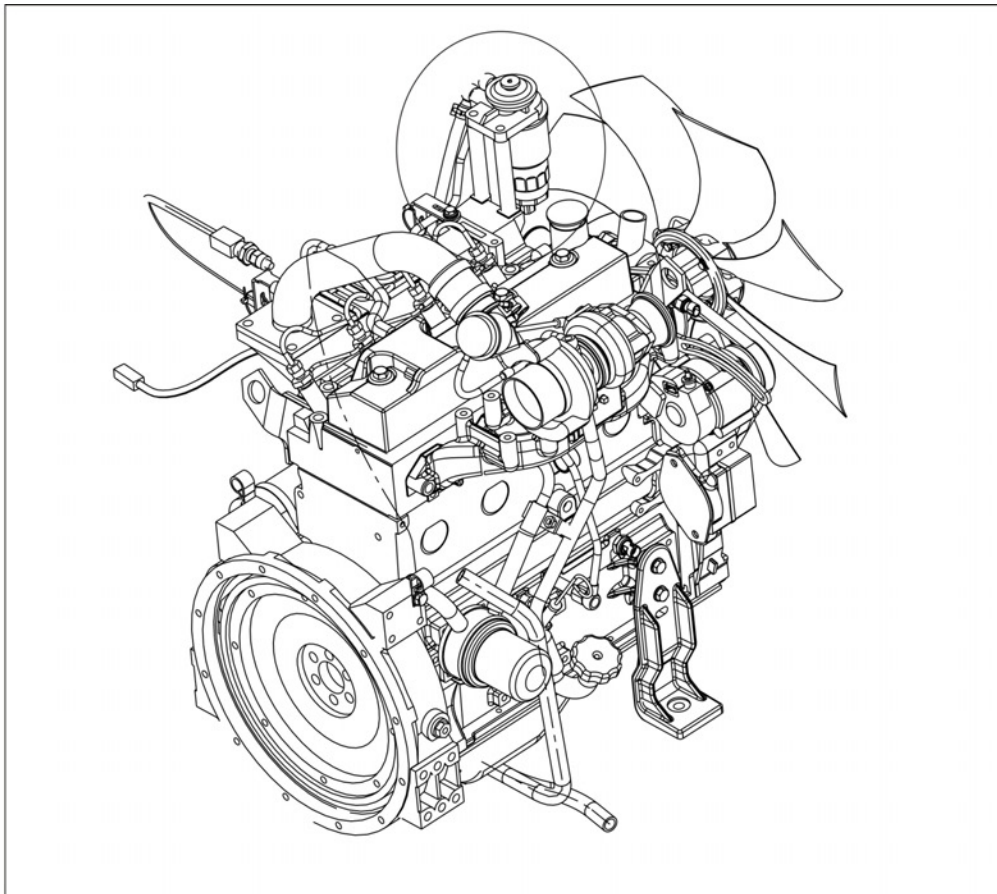

FIGURE 44. EXAMPLE OF FUEL/WATER SEPARATOR LOCATION

Fuel Filter Maintenance

Fuel Filter - Element Replacement

⚠ WARNING***Fuel Is Flammable***

When inspecting or performing service or repairs on the fuel system, to reduce the possibility of fire and resulting severe personal injury, death, or property damage.

Never smoke or allow sparks or flames (such as pilot lights, electrical switches, or welding equipment) in the work area.

NOTICE

Fuel filter replacement includes the appropriate o-ring and sealing grommet. The o-ring and grommet must be replaced with the filter element to make sure of proper operation.

NOTICE

The drained liquids must be disposed of in accordance with local environmental regulations.

1. Remove the existing filter.

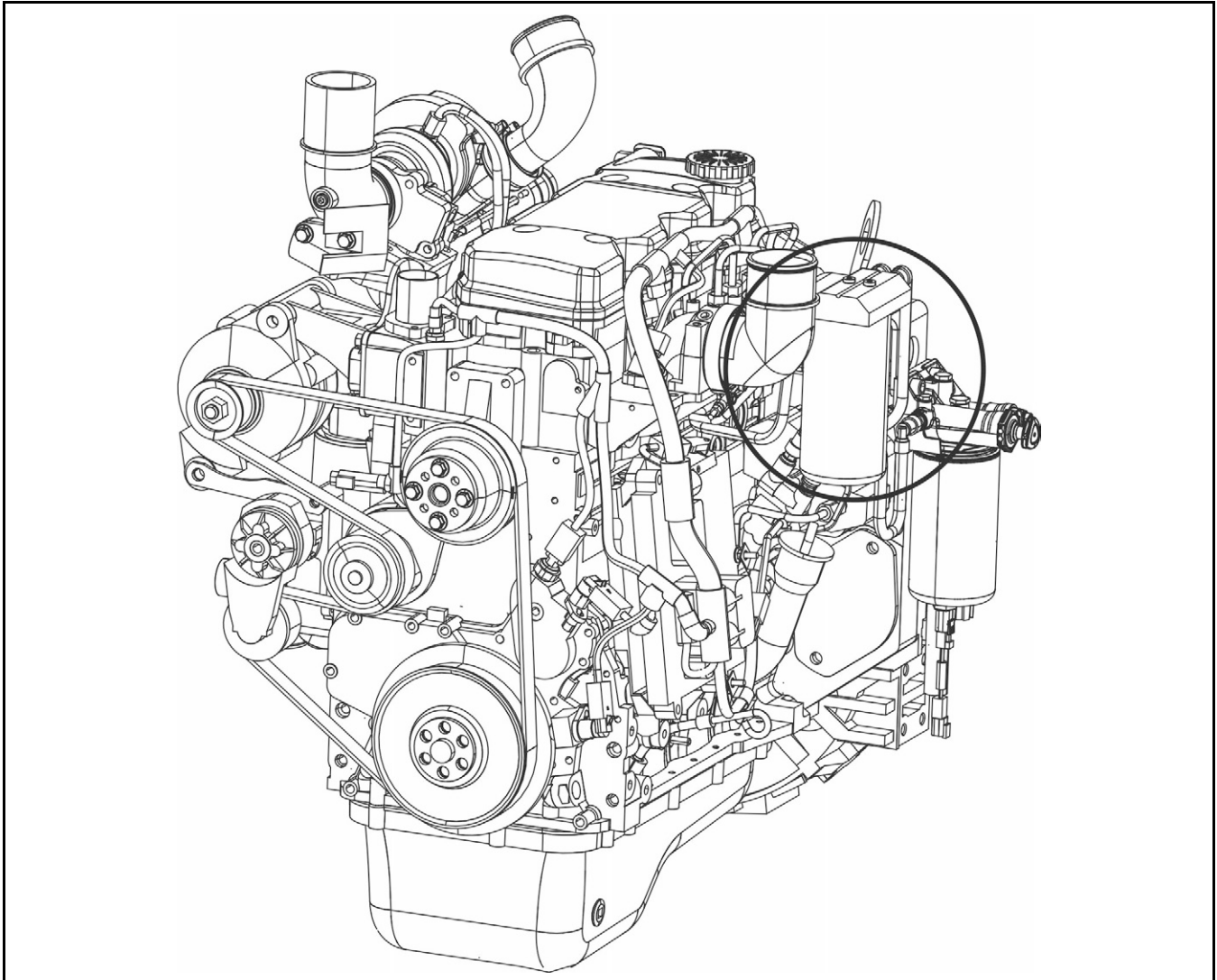

FIGURE 45. FUEL FILTER LOCATION

2. Fill the fuel filter with clean fuel.
3. Install the o-ring.
4. Install the fuel filter as specified by the filter manufacturer.

Hoses and Fuel Lines Check

⚠ WARNING

Moving Parts

Moving parts can cause severe personal injury or death.

Use extreme caution around moving parts. To prevent personal injury, turn off and remove power while troubleshooting.

⚠ WARNING

Hot Surfaces

Contact with the hot surfaces can cause severe burns.

Wear appropriate PPE when working on hot equipment and avoid physical contact with hot equipment where possible.

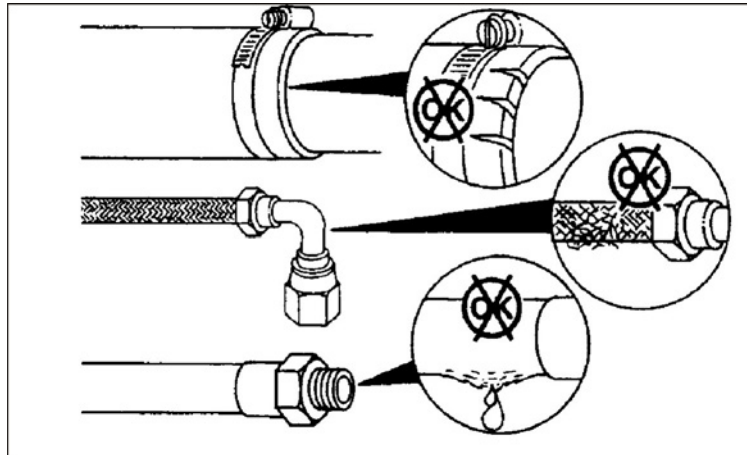

FIGURE 46. HOSES AND FUEL LINE INSPECTION

1. Inspect the fuel lines, filters, and fittings for leaks.
2. Check any flexible sections for cuts, cracks and abrasions and ensure they are not rubbing against anything that could cause breakage.
3. If any leaks are detected, shut down the generator set (if possible). Contact your authorized dealer and have the leaks corrected immediately.

5.6 Air Intake System

The direct flow air cleaner consists of a primary filter and a secondary filter within the air cleaner housing. The air cleaner has been designed for a maximum restriction, at which point the filter elements should be changed. Refer to the Model Specifications section.

Normal Duty Air Cleaner

Normal Duty Air Cleaner Element Replacement

NOTICE

Holes, loose-end seals, dented sealing surfaces, corrosion of pipes, and other forms of damage render the air cleaner inoperative and require immediate element replacement or engine damage can occur.

NOTICE

Cummins Inc. does not recommend cleaning paper-type air cleaner elements.

1. Remove the existing air cleaner:
 - a. Loosen the strap clamp (2).
 - b. Wipe away any debris accumulated around the air cleaner connection to the engine. Ensure that no debris is allowed to enter the body of the air cleaner or the connection on the engine.
 - c. Remove the dirty air cleaner (1).
 - d. Dispose of the dirty element in accordance with local environmental agency requirements.
2. Install the replacement air cleaner (1) as follows:
 - a. Install the air cleaner (1).
 - b. Tighten strap clamp (2). Torque to 2.5 - 3.3 ft-lb (4.3 - 4.65 Nm).

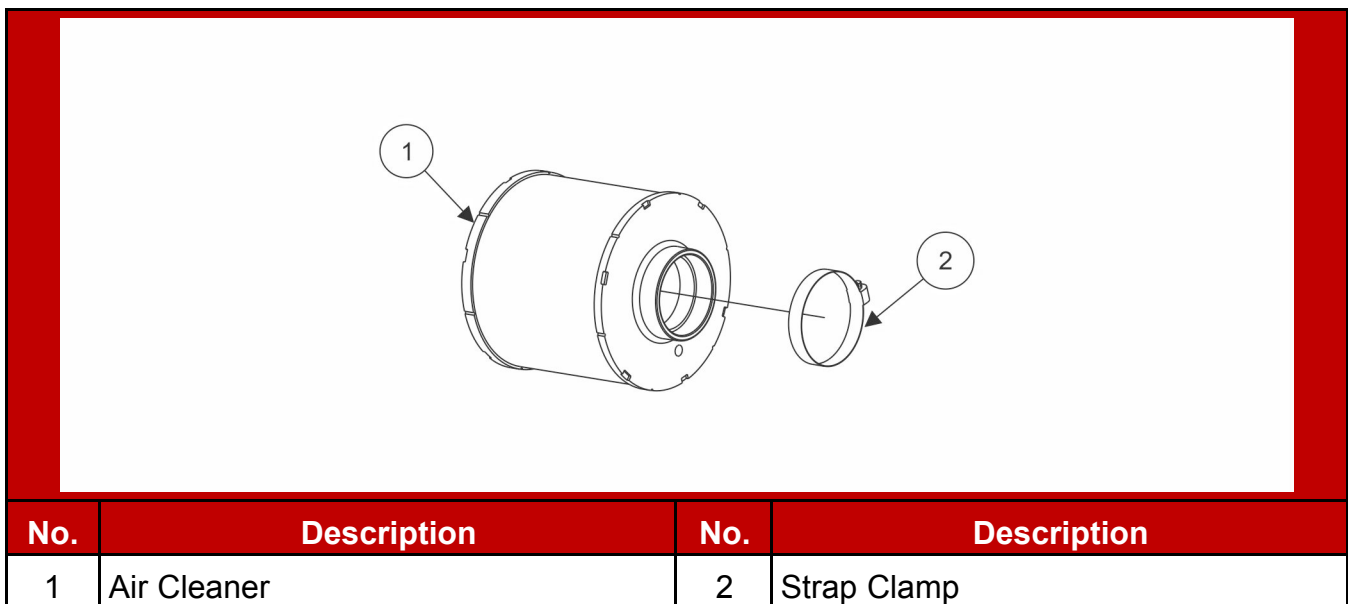

FIGURE 47. EXAMPLE OF NORMAL DUTY AIR CLEANER

Heavy Duty Air Cleaner

Air Cleaner Service Indicator

WARNING

Hot exhaust components.

Exhaust components become very hot when the generator set is in use and remain hot for a period of time after the generator set has been shut down. These components can cause severe personal injury or death from contact.

Allow these components to cool completely before performing any maintenance tasks.

WARNING

Moving parts.

Moving parts can cause severe personal injury or death.

Use extreme caution around hot manifolds, moving parts, etc.

The air cleaner service indicator, available only on heavy duty air cleaners, is located on the air cleaner assembly.

Check the air cleaner service indicator. If the gauge has crossed the red mark, replace the filter element.

Heavy Duty Air Cleaner Maintenance

WARNING

Fall Hazard

Falls can result in severe personal injury or death.

Make sure that suitable equipment for performing tasks at height are used in accordance with local guidelines and legislation.

There is a dust ejector valve (DEV) on the bottom of each filter pre-cleaner that should be checked periodically to make sure it is free of dust and dirt.

When there is a filter pre-cleaner, it includes a primary and secondary element that is checked periodically to make sure they are clean. Refer to the *Periodic Maintenance Schedule* table for additional information.

Heavy Duty Air Cleaner Element Replacement

CAUTION

Holes, loose-end seals, dented sealing surfaces, corrosion of pipes, and other forms of damage render the air cleaner inoperative and require immediate element replacement or engine damage can occur.

NOTICE

Cummins Inc. does not recommend cleaning paper-type air cleaner elements.

1. To remove the existing air cleaner element:
 - a. Before disassembly, wipe dirt from the cover and the upper portion of the air cleaner.
 - b. Lift the latch (3) and turn the end cover (4) counterclockwise.
 - c. Pull the end cover (4) away from the housing (1).
 - d. Remove the air filter element (2) from the housing (1).
 - e. Dispose of the dirty element in accordance with local environmental agency requirements.
2. To install the replacement air cleaner element:
 - a. Ensure that no debris enters the filter element or connection point on the air cleaner housing.
 - b. Insert the air filter element (2) into the housing (1).
 - c. Install the end cover (4) onto the housing (1).
 - d. Turn the end cover (4) clockwise until the latch (3) snaps into place.

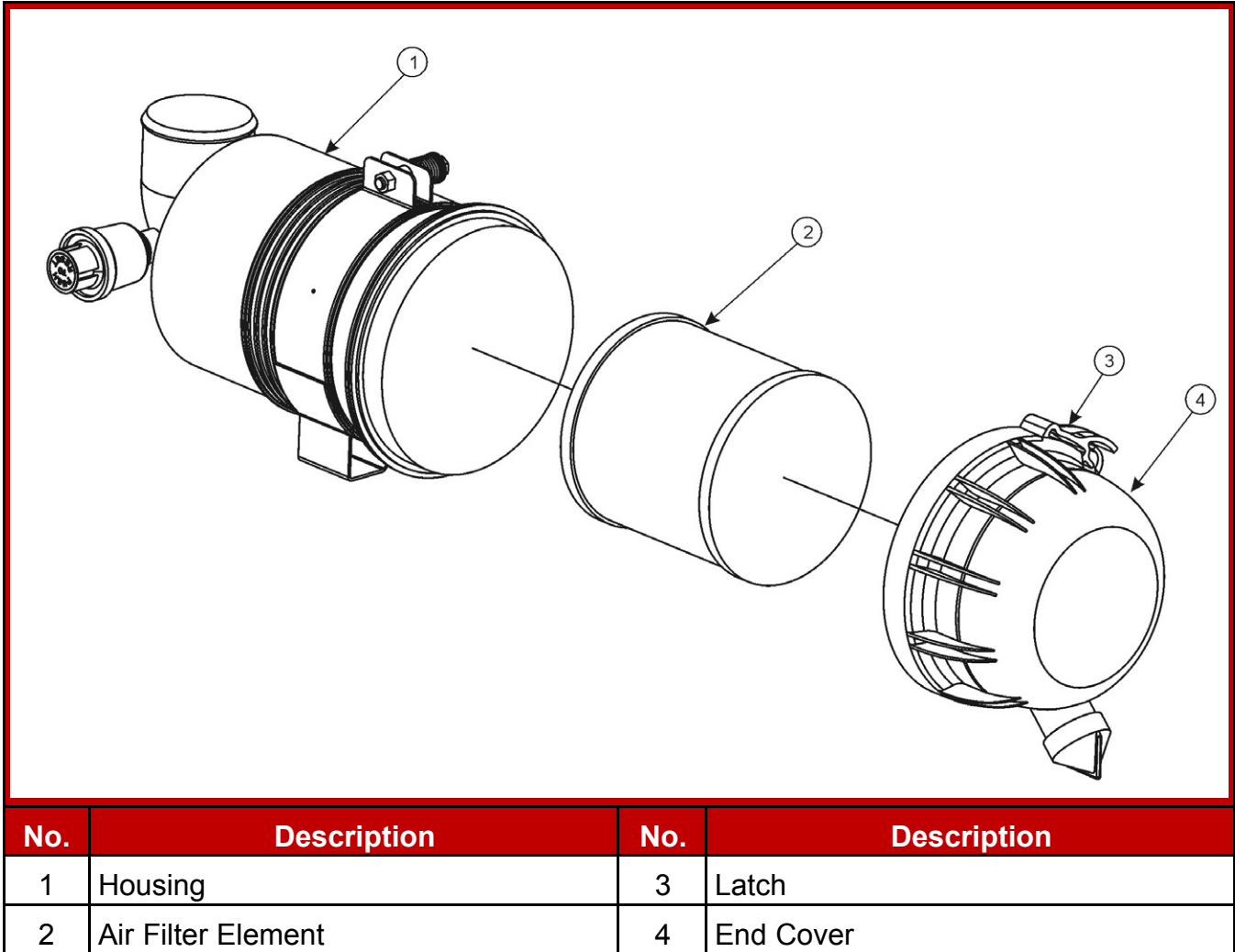

FIGURE 48. EXAMPLE OF HEAVY DUTY AIR CLEANER

5.7 Exhaust System Maintenance

⚠ WARNING

Hot Exhaust Components
Exhaust components become very hot when the generator set is in use and remain hot for a period of time after the generator set has been shut down. These components can cause severe personal injury or death from contact. Allow these components to cool completely before performing any maintenance tasks.

⚠ WARNING***Inhalation of Exhaust Gases***

Inhalation of exhaust gases can result in serious personal injury or death. Be sure deadly exhaust gas is piped outside and away from windows, doors or other inlets to buildings. Do not allow to accumulate in habitable areas.

⚠ WARNING***Moving Parts***

Moving parts can cause severe personal injury or death. Use extreme caution around moving parts, etc.

With the generator set operating, inspect the entire exhaust system visually and audibly including the exhaust manifold, muffler, and exhaust pipe without removing guarding and panels. Check for leaks at all connections, welds, gaskets and joints, and ensure that exhaust pipes are not heating surrounding areas excessively. If any leaks are detected, shut down the generator set (if possible). Contact your authorized dealer and have the leaks corrected immediately.

5.8 Generator Set Output - AC Electric System Checks

1. Check the following while the generator set is operating.

TABLE 20. AC ELECTRIC SYSTEM CHECKS

| Check | Description |
|--------------|--|
| Frequency | The generator set frequency should be stable and the reading should be the same as the generator set nameplate rating. See the Model Specifications section. |
| AC Voltage | At no load, the line-to-line voltage, or voltages, should be the same as the generator set nameplate rating. |
| AC Ammeter | At no load, the current readings should be zero. With a load applied, each line current should be similar. |
| Panel Lamps | When the operating panel is first connected to the DC supply, the system runs a check by illuminating each of the indicator lamps in turn. |

2. If all of the LEDs do not illuminate, replace the operator panel.

5.9 DC Electrical System

⚠ WARNING

Combustible Gases

Ignition of battery gases is a fire and explosion hazard which can cause severe personal injury or death.

Do not smoke, or switch the trouble light ON or OFF near a battery. Touch a grounded metal surface first before touching batteries to discharge static electricity. Stop the generator set and disconnect the battery charger before disconnecting battery cables. Using an insulated wrench, disconnect the negative (-) cable first and reconnect it last.

1. Check the harness connections. If any harness connections are damaged, contact your service representative.

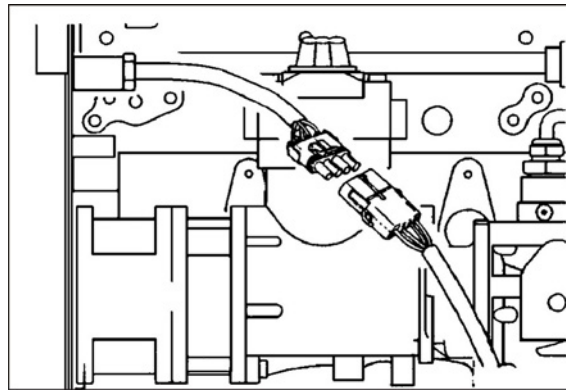

FIGURE 49. CHECK HARNESS CONNECTIONS

2. Check the terminals on the batteries for clean and tight connections. Loose or corroded connections create resistance, which can hinder starting. Clean and reconnect the battery cables if loose, using an insulated wrench. Always disconnect both ends of the negative battery cable. Reconnect one end of the cable to the negative battery terminal and the other end to ground. This will make sure that any arcing will be away from the battery and least likely to ignite explosive battery gases.
3. Check connections at the battery charging alternator.
4. Visually inspect the alternator belt to make sure it is not loose or cracked.

5.10 Batteries

Batteries are an essential part of any standby generator set system. A significant amount of generator set failures are due to battery issues.

It is therefore vital that batteries are stored, commissioned, and maintained as detailed here. Reference should also be made to the battery manufacturer's instructions.

Maintenance free batteries (if supplied with the generator set) need no maintenance for commissioning.

Storage

Batteries must be stored in a cool, dry, well-ventilated place, in the upright position, and with the vent caps securely in place.

Batteries must never be stacked on top of each other and must be protected from the floor by a wooden pallet or suitably thick cardboard sheet.

Safety Precautions

Servicing of batteries are to be performed or supervised by personnel knowledgeable of batteries and the required precautions. Keep unauthorized personnel away from batteries.

General Precautions for Maintenance-Free Batteries

Handling and proper use of batteries is not hazardous if the correct precautions are observed and personnel are trained in their use.

WARNING

Arcing Hazard

Laying tools or metal objects across the battery can cause arcing that may ignite battery gases causing explosions resulting in personal injury.

Never lay tools or metal objects across the top of the battery.

WARNING

Electric Shock Hazard

Voltages and currents present an electrical shock hazard that can cause severe burns or death.

Use tools with insulated handles to prevent the risk of electric shock.

CAUTION

Toxic Hazard

Electrolyte is a dilute sulphuric acid that is harmful to the skin and eyes. It is electrically conductive and corrosive.

Wear full eye protection and protective clothing. If electrolyte contacts the skins, wash it off immediately with water. If electrolyte contacts the eyes, flush thoroughly and immediately with water and seek medical attention. Wash spilled electrolyte with an acid neutralizing agent.

NOTICE

Keep batteries upright to prevent spillage.

Fire Hazard

WARNING

Combustible Gases

Lead acid batteries present a risk of fire because they generate hydrogen gas.

Do not smoke near the batteries. Do not cause flame or spark in the battery area. Discharge static electricity from your body before touching batteries by first touching a grounded metal surface.

WARNING

Before disconnecting a battery, always remove power from the AC powered battery charger.

WARNING

When putting a battery into service on a generator set, connect the negative lead LAST; when removing the battery, disconnect the negative lead FIRST.

Vented Batteries

WARNING

Toxic Hazard

The electrolyte in vented batteries is a dilute sulfuric acid that is harmful to the skin and eyes. It is also electrically conductive and corrosive.

Always:

- 1. Wear full eye protection and protective clothing;**
- 2. If the electrolyte contacts the skin, wash it off immediately with water;**
- 3. If the electrolyte contacts the eyes, flush them thoroughly and immediately with water and seek medical attention; and**
- 4. Wash spilled electrolyte down with an acid neutralizing agent. A common practice is to use a solution of one pound (500 grams) bicarbonate of soda (also known as baking soda or sodium bicarbonate) to one gallon (4 liters) of water.**
- 5. Continue to add the bicarbonate of soda solution until the evidence of reaction (that is, foaming) has stopped.**
- 6. Flush the resulting liquid with water and dry the area.**

Battery Maintenance

WARNING

Automated Machinery

Accidental or remote starting of the generator set can cause severe personal injury or death. Arcing at battery terminals or in light switches or other equipment, and flames or sparks can ignite battery gas causing severe personal injury.

Always follow these procedures to avoid injury and/or damage:

- ***Ventilate the battery area before working on or near the battery.***
- ***Wear safety glasses.***
- ***Do not smoke.***
- ***Switch a work light on or off away from the battery.***

Make sure the generator set is shut down and disabled:

1. ***Press the generator set's red STOP button on the local display to stop the generator set. Allow the generator set to thoroughly cool to the touch.***
2. ***Turn off and disconnect the battery charger from the AC source before disconnecting the battery cables.***
3. ***Disconnect the negative (-) cable from the battery and secure it from contacting the battery terminals to prevent accidental starting.***
4. ***Once work is complete, reconnect the negative (-) battery cable last.***

See *Battery Charger Maintenance* for troubleshooting the charger.

Always:

- Keep the battery case and terminals clean and dry and the terminals tight.
- Remove battery cables with an insulated wrench or battery terminal puller.
- Make sure which terminal is positive (+) and which is negative (-) before making battery connections, always removing the negative (-) cable first and reconnecting it last to reduce arcing.

NOTICE

If the battery needs to be replaced, make sure that the replacement battery specifications match those found in the Model Specifications in this manual.

Charging

Where a consistent source of AC power is available, Cummins recommends the use of a battery charger to maintain battery condition and charge. Cummins offers several battery chargers.

Where generator sets are used infrequently and a consistent source of AC power is not available, battery recharging must be put on a recharge schedule to ensure that a fully charged condition is maintained.

NOTICE

NEVER allow a battery to become completely flat (fully discharged), or to stand in a discharged condition, or damage will result.

Follow the battery charger operating instructions for proper use.

Battery Replacement

⚠ WARNING***Combustible Liquid***

Burning the battery may cause an explosion. Damage to the casing will release electrolytes which is harmful to the skin and eyes.

When disposing of a battery, do not mutilate or burn it. Comply with all local health and safety regulations/codes during handling or disposal.

Always replace the starting battery with the same number and type (e.g., vented, lead acid, maintenance free) as listed in the specifications section of this document. Properly dispose of battery in accordance with local environment agency requirements.

Always use correct handling techniques to lift and move a battery.

5.11 Cleaning the Generator Set Housing

The housing of the generator set housing can be damaged by pressure washing or solvents and other cleaning agents. Only use soap and water or an "all citrus degreaser" to clean the housing.

5.12 Complete System Test

NOTICE

Only authorized and qualified maintenance technicians who are familiar with the equipment and its operation should carry out this test.

A complete system test is recommended to verify that the electrical system is working properly. Testing the system once every 200 hours or every 2 years is required to make sure the transfer switch will transfer the load to the generator set if there is a utility power failure. For more information, see the transfer switch owner manual.

To initiate a complete system test:

1. Before starting:
 - Check the oil level.
 - Make sure there is enough fuel.
 - See the Checklist section in the installation manual.
2. Place the generator set in Standby mode.
3. Switch the main utility disconnect from the ON to the OFF position.
4. Make sure the following occurs:
 - a. The generator set starts.
 - b. After the generator set starts and stabilizes, the load is transferred from the utility to the generator set.
5. Switch the main utility disconnect from the OFF to the ON position.
6. Make sure the following occurs:
 - a. After approximately 5 minutes, the load is transferred back to the utility.
 - b. Once the transfer switch is connected to utility power, after approximately 5 minutes, the generator set stops.

NOTICE

If the test fails, call your authorized Cummins service provider to fix the problem.

6 Troubleshooting

6.1 Fault Code Introduction

Fault code information, together with warning and shutdown information, is provided in this section to assist in locating and identifying the possible causes of faults in the generator set system.

Refer also to the engine-specific operator manual, if it exists. The engine operator manual contains additional information regarding the running and care of the generator set as well as specific equipment instructions that may differ from the standard generator set.

For any fault codes that occur but are not listed, contact your Cummins service representative.

6.2 Avoiding Generator Set Shutdowns

By regularly performing the following periodic maintenance and guidelines, you will greatly reduce the chances of a generator set shutdown:

- Maintain an appropriate oil level.
- Keep battery connections clean and tight.
- Do not overload the generator set.
- Keep the air inlet and outlet openings clear.

Refer to the Maintenance section for more information.

6.3 Control System

The generator set control system continuously monitors engine sensors for abnormal conditions, such as low oil pressure and high coolant temperature. If any of these conditions occur, the control will light a yellow Warning lamp or a red Shutdown lamp and will display a message on the graphical display panel. In the event of an engine shutdown fault (red Shutdown LED), the control will stop the engine immediately.

6.4 Safety Considerations

WARNING

Hazardous Voltage

Contact with high voltages can cause severe electrical shock, burns, or death.

Make sure that only personnel who are trained and qualified to work on this equipment are allowed to operate the generator set and perform maintenance on it.

WARNING

Automated Machinery

Accidental or remote starting of the generator set can cause severe personal injury or death.

Make sure that the generator set cannot be started accidentally or remotely before starting work on the generator.

WARNING

Combustible Gases

Ignition of battery gases is a fire and explosion hazard which can cause severe personal injury or death.

Do not smoke, or switch the trouble light ON or OFF near a battery. Touch a grounded metal surface first before touching batteries to discharge static electricity. Stop the generator set and disconnect the battery charger before disconnecting battery cables. Using an insulated wrench, disconnect the negative (-) cable first and reconnect it last.

CAUTION

Hazardous Voltage

Contact with high voltages can cause severe electrical shock, burns, or death.

Isolate all external electrical supplies prior to access of the control panel. Internal components have live exposed terminations even when the generator set is not running.

NOTICE

Isolator switch only: Do not open the output box while the generator set is running as the isolator switch will cause the generator set to shut down. Keep the output box covers in place during troubleshooting.

NOTICE

Always disconnect a battery charger from its AC source before disconnecting the battery cables. Failure to do so can result in voltage spikes high enough to damage the DC control circuits of the generator set.

NOTICE

Ventilate the battery area before working on or near the battery. Wear goggles. Stop the generator set and disconnect the battery charger before disconnecting the battery cables using an insulated wrench. Disconnect the negative (-) cable first and reconnect it last.

All maintenance tasks must be assessed for health and safety risks; the preventive measures identified must be performed. An additional person is required for any task where doing so significantly adds to the safety of the task.

The installation of a generator set can be designed for remote starting. When troubleshooting a generator set that is shut down, make sure that the generator set cannot be accidentally re-started. Refer to the Locking the Generator Set Out of Service section.

6.5 Fault Finding

⚠ WARNING

Troubleshooting procedures.

Troubleshooting procedures present hazards that can result in severe personal injury or death.

Only qualified service personnel with knowledge of fuels, electricity, and machinery hazards should perform service procedures.

Review safety precautions listed in this manual together with the documentation supplied with the generator set.

For any symptom not listed, contact your authorized dealer for assistance.

Before starting any fault finding, ensure that the following basic checks are carried out:

- All switches and controls are in their correct positions
- Fuel system is connected and fuel is available
- The lubricating oil level is correct
- The coolant level is correct
- The radiator cooling air flow is free from obstruction
- The battery charge condition is satisfactory and the connections are secure
- The generator set electrics and alternator connections are secure
- The panel connections are secure

- The protection circuits have been reset
- Blown fuses have been replaced
- Tripped contactors or circuit breakers have been reset

6.6 Engine Does Not Crank in Manual Mode (No Fault Message)

Possible Cause:

1. Battery voltage

Diagnosis and Repair:

1. Battery voltage.
 - a. Check the battery connections.
 - b. Verify the battery charge.

6.7 Code 143 - Engine Oil Pressure Low (Warning)

Logic: Engine oil pressure is below the low oil pressure shutdown threshold.

Possible Cause:

1. Low lubricating oil level
2. External leak

Diagnosis and Repair:

1. Low lubricating oil level
 - a. Check the oil level. Add or drain oil, if necessary.
2. External leak
 - a. Inspect the engine and surrounding area for external oil leaks.
 - b. Contact your local dealer if a leak is present.

6.8 Code 146 - Engine Coolant Temperature Above Normal (Warning)

Logic:

Engine coolant temperature has exceeded the alarm (warning) threshold for high coolant temperature.

Possible Cause:

1. High ambient temperature
2. Coolant level is below specification
3. Cooling system components are damaged or obstructed

Diagnosis and Repair:

1. High ambient temperature
 - a. Reduce loads or recirculation of discharge air to generator in elevated ambient.
2. Coolant level is below specification
 - a. Inspect the engine, cooling system, and surrounding area for external coolant leaks.
 - i. Add coolant as necessary.
 - ii. Contact your local dealer if a leak is present.
3. Cooling system components are damaged or obstructed
 - a. Inspect radiator, charge air cooler, and other cores (if used).
 - i. Check for damaged fins.
 - ii. Inspect for dirt, debris, or obstructions.
 - iii. Remove blockages.
 - b. Inspect fan shroud and air recirculation baffles for damage and clearance.
 - i. Contact your local dealer if repair or replacement is required.
 - c. Inspect fan belt(s) for damage, wear, and proper tension. Inspect pulleys and belt tensioner for damage or wear.
 - i. Contact your local dealer if repair or replacement is required.
 - d. Inspect radiator cap and gasket for damage and proper pressure operation.
 - i. Contact your local dealer if repair or replacement is required.
 - e. Inspect upper and lower radiator hoses for collapse, distortion, or fluid leaks.
 - i. Contact your local dealer if repair or replacement is required.
 - f. Inspect cooling system components for internal contaminants (dirt, scale, or sludge) and clean as required.
 - i. Open the radiator cap and inspect for contaminated coolant and scale.
 - ii. Contact your local dealer if flushing of cooling system is required.

6.9 Code 151 - Engine Coolant Temperature High (Shutdown)

Logic:

Engine coolant temperature has exceeded the alarm (shutdown) threshold for high coolant temperature.

Possible Cause:

1. High ambient temperature

-
2. Coolant level is below specification
 3. Cooling system components are damaged or obstructed

Diagnosis and Repair:

1. High ambient temperature
 - a. Reduce loads or recirculation of discharge air to generator in elevated ambient.
2. Coolant level is below specification
 - a. Inspect the engine, cooling system, and surrounding area for external coolant leaks.
 - i. Contact your local dealer if a leak is present.
 - b. Verify the coolant level is correct via the sight glass.
 - i. Add coolant as necessary.
3. Cooling system components are damaged or obstructed
 - a. Inspect the radiator, charge air cooler, and other cores (if used).
 - i. Inspect for damaged fins.
 - ii. Inspect for dirt, debris, or obstructions.
 - iii. Remove blockage.
 - b. Inspect the fan shroud and air recirculation baffles for damage and clearance.
 - i. Contact your local dealer if repair or replacement is required.
 - c. Inspect the fan belt(s) for damage, wear, and proper tension. Inspect pulleys and belt tensioner for damage or wear.
 - i. Contact your local dealer if repair or replacement is required.
 - d. Inspect the radiator cap and gasket for damage and proper pressure operation.
 - i. Contact your local dealer if repair or replacement is required.
 - e. Inspect upper and lower radiator hoses for collapse, distortion, or fluid leaks.
 - i. Contact your local dealer if repair or replacement is required.
 - f. Inspect cooling system components for external contaminants and clean as required.
 - i. Open the radiator cap and inspect for contaminated coolant and scale.
 - ii. Contact your local dealer if flushing of cooling system is required.

6.10 Code 415 - Engine Oil Pressure Low (Shutdown)

Logic: Engine oil pressure is below the low oil pressure shutdown threshold.

Possible Causes:

1. Lubricating oil level is low
2. External leak

Diagnosis and Repair:

1. Lubricating oil level is low
 - a. Check the oil level. Add oil, if necessary.
2. External leak
 - a. Inspect the engine and surrounding area for external oil leaks.
 - b. If a leak is present, contact your Cummins service representative.

6.11 Code 441 - Battery Voltage Low (Warning)

Logic:

Battery voltage low.

Possible Causes:

1. Damaged battery cable connections

Diagnosis and Repair:

1. Inspect the battery cable connections for loose connections, corrosion, and repair as necessary.

6.12 Code 1317 - Coolant Level Low (Warning or Shutdown)

Logic:

Coolant level sensor signal is showing a low coolant level for greater 10 seconds.

Possible Causes:

1. Low coolant

Diagnosis and Repair:

1. Low coolant
 - a. Stop the engine and allow the engine to cool down.
 - b. Visually inspect and verify that the engine coolant is at the appropriate level.
 - c. If the coolant level is too low, add coolant per specifications.

6.13 Code 1318 - Low Fuel (Warning or Shutdown)

Possible Causes:

1. Low fuel level
2. Faulty or inoperable switch

Diagnosis and Repair:

1. Low fuel level
 - a. Add the manufacturer's prescribed fuel.
2. Faulty or inoperable switch
 - a. Remove the switch and verify proper switch operation. If either of the following conditions is demonstrated, the switch is defective:
 - When the float is at the bottom of the switch, the wires do not show continuity.
 - When the float is raised, the wires do not show an open circuit.
 - b. Contact your local dealer if repair or replacement is required.

6.14 Code 1438 - Fail to Crank (Shutdown)

Logic:

The engine failed to crank after the generator set control received a start signal.

Possible Cause:

1. Dead or weak battery

Diagnosis and Repair:

1. Dead or weak battery
 - a. Verify battery voltage is at least 12 VDC (24 VDC where applicable).
 - b. Charge or replace the battery as necessary.

6.15 Code 1471 - High AC Current (Warning)

Logic:

The generator set output current has exceeded the warning limit threshold for greater than the fixed time delay.

Possible Causes:

1. Generator set overload

Diagnosis and Repair:

1. Generator set overload.
 - a. Reduce the generator set load by powering off unnecessary electrical loads.

6.16 Code 1472 - High AC Current (Shutdown)

Logic:

The generator set output current has exceeded the shutdown limit threshold for greater than the fixed time delay.

Possible Causes:

1. Generator set overload

Diagnosis and Repair:

1. Generator set overload.
 - a. Reduce the generator set load by powering off unnecessary electrical loads.

6.17 Code 5134 - Unknown Shutdown at Idle

Logic:

Engine is not getting a proper fuel supply.

Possible Causes:

1. Fuel supply issue

Diagnosis and Repair:

1. Fuel supply issue
 - a. Check that there is a proper supply of fuel to the engine.

6.18 Status Indicators - PowerCommand 1.1

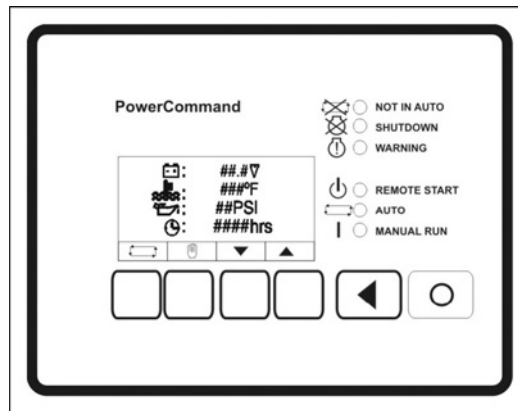

FIGURE 50. OPERATOR PANEL

Not in Auto

This red lamp is lit when the control is not in Auto.

Shutdown Status

This red lamp is lit when the control detects a Shutdown condition. The generator set cannot be started when this lamp is on. After the condition has been corrected, the lamp can be reset by pressing the **Off** button.

NOTICE

When Battle Short mode has been enabled and an overridden shutdown fault occurs, the Shutdown lamp will be lit even though the generator set will continue to run.

Warning

This yellow lamp is lit whenever the control detects a Warning condition. This lamp is automatically shut off when the Warning condition no longer exists.

Remote Start

This green lamp indicates the control is receiving a Remote Run signal.

Auto

This green lamp indicates the control is in **Auto** mode. **Auto** mode can be selected by pressing the  selection button from any of the Operator menus.

Manual Run

This green lamp indicates the control is in the **Manual Run** mode. **Manual Run** can be selected by pressing the  selection button from any of the Operator menus.

6.19 Fault/Status Codes - PowerCommand 1.1

Fault/Status Codes Warnings

WARNING

Electrical Generating Equipment

Incorrect installation or servicing can result in severe personal injury or death.

Make sure that only suitably trained and experienced service personnel with knowledge of fuels, electricity, and machinery hazards perform electrical and/or mechanical service.

WARNING

Automated Machinery

Accidental or remote starting of the generator set can cause severe personal injury or death.



Prevent accidental starting by disconnecting the starting battery cables, negative (-) cable first.

Fault Messages

A Fault message is an indicator of a Warning or Shutdown condition. It includes the fault type (Warning or Shutdown), fault number, and a short description. It also includes where the fault occurred if the generator set control did not detect the fault and is simply reporting the fault.

Active and acknowledged faults may be viewed in the Faults menu.

Fault Acknowledgement

Shutdown faults must be acknowledged after the faults have been corrected. If in Auto or Manual Run mode, the control must be set to "O" (off). Also, faults are acknowledged when in Auto and the Remote Start command is removed. Faults are cleared from the operator panel display by pressing the , , or  button.

Faults are re-announced if they are detected again after being acknowledged.

6.20 Line Circuit Breaker

A line circuit breaker is mounted in the generator output box. If the load exceeds the circuit breaker current rating, the line circuit breaker will open, preventing the generator from being overloaded. If the circuit breaker trips, locate the source of the overload or short circuit, and correct as necessary. Manually reset the breaker to reconnect the load to the generator.

Line Circuit Breaker Location

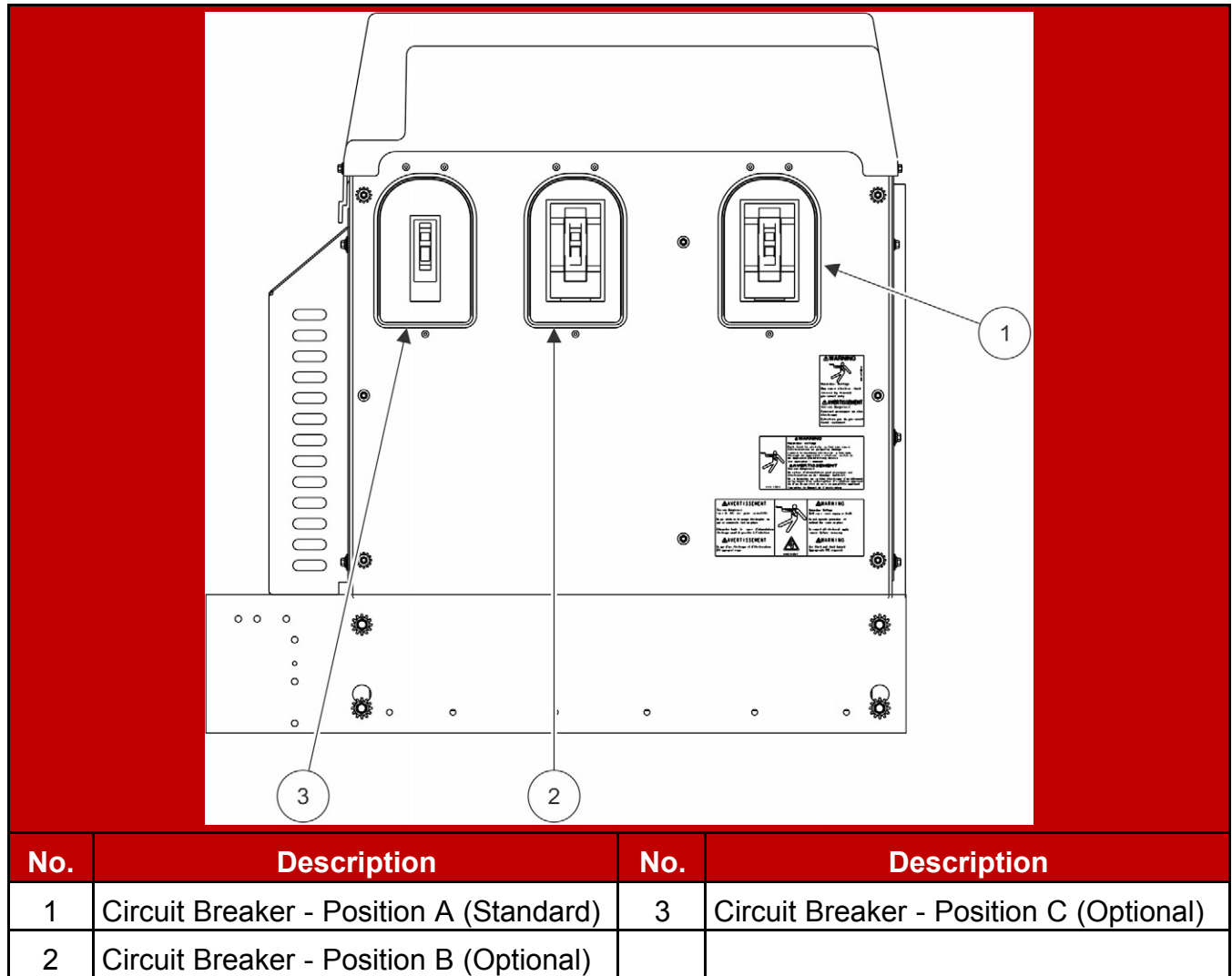

FIGURE 51. LINE CIRCUIT BREAKER LOCATION

power.cummins.com

Copyright © 2018 Cummins Inc. All rights reserved.

Cummins, the "C" logo, PowerCommand, AmpSentry, and InPower are trademarks of Cummins Inc.

Other company, product, or service names may be trademarks or service marks of others.

Specifications are subject to change without notice.

